

**Head Office**

Buro Happold  
Camden Mill  
Lower Bristol Road  
Bath  
BA2 3DQ  
ENGLAND

Telephone: 0225-337510 (10 lines)  
Telex: 449798 Burhap G  
Fax: 0225-311779

**Affiliated Offices****London**

Buro Happold  
23/27 Heddon Street  
London  
W1R 7LG  
ENGLAND

Telephone: 01-439-7314

**Kuwait**

Buro Happold  
PO Box 36666  
Ras Salmiyah  
KUWAIT

Telephone: 010-965-2410288

**New York**

Buro Happold  
157 Chambers Street  
New York City  
NY 10007  
USA

Telephone: 010-1-212-732-4691

**Riyadh**

Buro Happold  
Riyadh  
SAUDI ARABIA

Telephone: 010-9661-4784244

**Hong Kong**

Buro Happold  
12/F, Shiu Lam Building  
23 Luard Road  
Wanchai  
HONG KONG

Telephone: 010-8525-295508

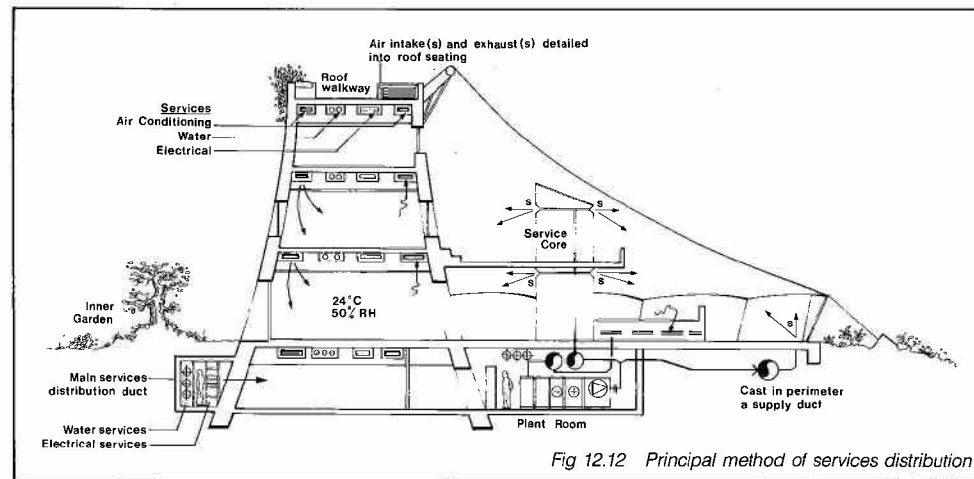

Fig 12.12 Principal method of services distribution

were restricted in size depending on the floor level and had to be integrated into the elliptical openings on the wall elevations or into the roof scape details. The intensity of the local sandstorms dictated the need for fitting sand louvres on both the supply and exhaust openings.

Roof outlets were confined to specific areas as the roof itself was designed as a walkway which users of the Club could use to view the Wadi Hanifa. This use greatly restricted the positioning of servicing elements on the roof. Gravity water systems were totally excluded with the result that all water systems used pressurized mains supply. Concrete water tanks are provided in the north tail of the wall and duplicate pressurizing pumps maintain a cold water system at 4 bar. Cold (and hot) water pipework is totally in copper. A similar system is provided for irrigation supplies. The local infrastructure for the Diplomatic Quarter provides both supplies ie potable water and treated effluent water, storage being necessary to reduce peak demands on the systems and to provide a reserve in the event of mains failure.

The points of demand for hot water services in the building are very localised and local electric water heaters were considered more economical than a central system. Some of the heaters are large in capacity and in their demand for electricity, and to limit power surges on the mains full power, can only be provided during the night.

The main chiller compound is located remote from the building to eliminate the visual impact on it and to remove what could have been a disturbing noise source. Five air cooled chillers are installed in the compound with a total cooling capacity of 2.6MW. Chilled water at 6°C (13°C return) is pumped to the building via a 2m x 2m underground service duct which skirts the buildings and links all plantroom locations. The chilled water mains are connected as a reverse return system, the aim being to ease commissioning on the extensive network. In addition to the chilled water mains the service duct also transports water, fire and electrical mains.

The building is totally electric with the exception of the LPG system which supplies kitchen equipment and hot water boilers for the hotel zone. Electricity however, represents over 95% of the energy input. The incoming supply from the Diplomatic Quarter water infrastructure is at 13.8KV which is transformed down to 220 volts, 3 phase, 60 cycles for distribution. Four 1.0 MVA transformers provide for the building load. Seasonal demand is given in Table 2 below.

The low voltage of the building distribution system (220V, 3 phase and 120V single phase) plus the linear form of the building produced voltage drops which led to considerable design problems. This, coupled with the high ambient operating temperatures resulted in a design decision for the use of mineral insulated cables. After initial

problems in its installation by the Korean contractors, the final result was a very successful and neat installation.

Stand by generation for emergency services is provided by a 750 KVA mains failure diesel engine which is located adjacent to the chiller compound and provides emergency power to lighting, computers, exhaust fans and lifts. All passenger lifts are hydraulic; again the restriction on head height dictated their use.

A Honeywell Delta 1000 building management system has been installed. This monitors the power input and limits its consumption in the building; controls HVAC plant and lighting; monitors the fire alarm system and controls fire audibility signals; and releases smoke doors and smoke dampers whilst activating ventilation fans.

In conclusion, it is the contrast of lightweight and massive building 'skins' that highlights the Diplomatic Club and relates it back to traditional Arabian architecture.

In addition to the authors many other members of staff were involved in the Diplomatic Club project. Contributors included Ted Happold, Ian Liddell, Peter Buckthorp, Rodger Webster, Eddie Pugh and David Wakefield.



Fig 12.13 Building skins of stone & fabric

Terry Ealey, Vincent Grant, Mick Green & Tony McLaughlin

Description	Four Season	Winter	Summer	Total
Actual Load	1,713,600	1,960,000	1,796,900	4,979,400
Demand Load	1,542,300	1,764,100	1,605,600	3,901,300

Table 2 Transformer Loads (Va)

Ten Years Overseas	Edmund Happold	2
Working Overseas - Organisation & Management	Peter Buckthorp	4
KOCOMMAS	Terry Ealey & Rod Macdonald	5
Construction Analysis - Unconventional Structures	Rodger Webster	6
The Al Marzook Centre for Islamic Medicine, Kuwait	John Morrison & Terry Ealey	8
Working in Iraq	Rod Macdonald	10
National Museum of Archaeology, Amman	Michael Dickson & Mike Shaw	13
ADF Sports Centre, Jeddah	Brian Cole & Ian Liddell	15
A Covered Northern Township, Alberta	Ian Liddell	16
Developments in Fabric Structures	Ian Liddell, David Wakefield & Mike Cook	18
Four Neighbourhood Mosques for the Diplomatic Quarter, Riyadh	Ian Duncan	19
Diplomatic Club, Riyadh	Terry Ealey, Vincent Grant, Mick Green & Tony McLaughlin	20

The Partners wish to record that without co-operation from professional colleagues and the trust of our clients, the work undertaken by the practice to date would not have been possible. To them the practice expresses its thanks and gratitude.

#### Note from the Editors

This first issue of Patterns illustrates some of the engineering aspects of the practice's work overseas which have contributed to the recent Queen's Award for Export Achievement. Overseas work is only part of the practice's effort. Our next task as editors is to assemble a companion issue describing some of the commissions in the United Kingdom carried out since the practice started ten years ago.

Editor Robbie McElhinney  
Technical Editor Michael Dickson

Design Christian Hills Design  
Filmsetting Sulis Typesetting  
Print The Midway Press



That the first issue of a practice journal describes ten years of engineering work abroad is, in itself, a success. In that time the practice has grown from a broken down house in Gay Street, Bath with only the partners, Eddie Pugh as an engineer, Tony Waters as the draughtsman, and Mike Cook as a student working in his vacation, to its present size of about a hundred in the UK, not including all those overseas. But when that decade of work is being recognised by a Queen's Award for Export Achievement presented by Sir John Wills, Lord Lieutenant of Avon, in October of this year, there is some justification for a little pride by all of us.

This practice started from a belief that seeing art and engineering as divided is not seeing the world as a whole – that architecture, being primarily an art dependent on precedent, and engineering, being primarily the study of science and its use in construction, should be a partnership. Design requires both disciplines to ensure a wide range of different values go into the product. But this will not occur unless both disciplines understand and respect the need for these qualities.

Twelve years ago Bath University offered me the chance of building a joint school of architecture, civil/structural and building services engineering. I had always believed that those who subsequently will work together should be taught together and that a knowledge of how others work is essential to enjoyable and successful collaboration. That the post also included the freedom to do some design encouraged my acceptance.

Ian Liddell, Peter Buckthorp, John Morrison, Michael Dickson, Rod MacDonald, Terry Ealey and John Reid supported that idea and on 1 May 1976 we started a structural engineering practice. I had an old and successful relationship with the architects Rolf Gutbrod and Frei Otto (Fig 1.1) and our first job was the engineering of the King's Office, Council of Ministers and Majilis Al Shura for Riyadh which we shared with Ove Arup and Partners. We had a discussion on what to call the practice. I argued for a non personalised title, others asked for it to include my name. Rolf Gutbrod's office was called Buro Gutbrod so Ian Liddell suggested Buro Happold. So a constant source of misunderstanding was born. If strangers don't address me as Buro, they usually ask to meet him. If none of my partners is around to accept the name, I usually say 'Deceased, I'm afraid'.

But the relationships with Gutbrod, Otto and Saudi Arabia have not deceased. KOCOMMAS dominated the office, John Reid went to Saudi Arabia and the project got as far as having all its infrastructure and support buildings completed before it was stopped. Subsequently John Reid went back to his mill in County Durham. Gutbrod and Otto were then commissioned for a Sports Hall

for the King Abdul Aziz University in Jeddah. With Gutbrod we went on to act as engineers for the Cultural Centre in Baghdad. Gutbrod introduced us to James Stirling; we sketch-schemed the Stuttgart Staatsgalerie.

With Frei Otto we had developed a range of lightweight structures design over many years. He introduced us to the US practice of Sprankle Lynd and Sprague and we jointly worked on the design of the Town Centre Buildings for Vail in Colorado and at Gatlinburg, Tennessee. Rodger Webster joined the partnership from contracting and enabled us to analyse and control these constructions.

With Frei Otto and Sprankle Lynd and Sprague we entered the competition for the Diplomatic Club in Riyadh. This complex was subsequently redesigned and carried out with Otto and the Riyadh architectural practice of Omrania. With Frei Otto we have engineered a whole range of structures including the Pink Floyd brollies (Fig 1.2), the Munich Aviary, water dams and even airships.

Many of these projects were covered with long span flexible structures and a research unit was formed at the University of Bath to study the design of airhouses. In those days the body of knowledge about flexible structures was very limited and, although many analysts were publishing papers they based them on traditional assumptions. Then Roland Mainstone at BRE monitored an airhouse and the stress readings he got varied from current theory by a factor of two. Michael Dickson visited me at Arnside and we walked up and down the beach trying to understand it and suddenly realised that all theory assumed a constant uniform pressure, correct overall but ignoring that it varied locally internally in response to the wind.

I took a special research fund grant from the University and Buro Happold provided the rest of the funds to take on Mike Cook at the University to go round all airhouses in Europe observing and reviewing their behaviour and modes of failure. That led to a very large interactive research group being formed which attracted Wolfson Foundation and SERC grant funding. The work of the group (which included from the present practice, Ian Liddell, Michael Dickson, Mike Barnes, Peter Moseley and Mike Cook) is worthy of another story but, suffice it to say, it radically advanced the state of the art. There is no doubt that the success of this work was due to the interaction of the designers and the researchers. Ian Liddell and David Wakefield have gone on to realise and extend these advances.

Physical modelling was important in those early days and Denis Hector, a post-graduate architect from the USA who had been working with Frei Otto, came over from Germany to advance this



Fig 1.1 Frei Otto and Rolf Gutbrod

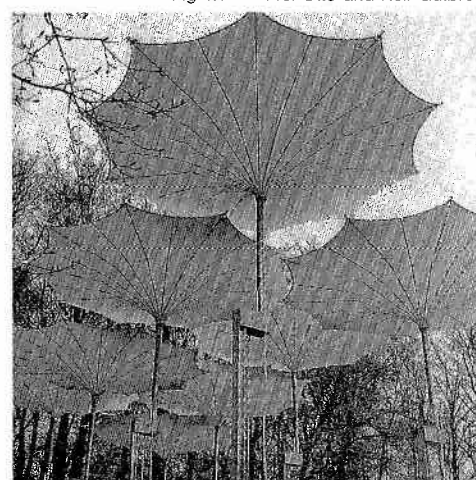

Fig 1.2 Pink Floyd stage covering, US tour 1978

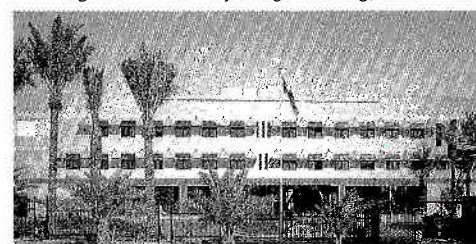

Fig 1.3 British Embassy in Riyadh, Saudi Arabia

designed. Many wall openings were required, and their arrangement could not be standardised. Continuity was required throughout much of the wall construction in order to resist the applied side loads from tent attachments, and since the wall was continuously anchored to the ground a close spacing of movement joints in the walls would have been required for the joints to be effective. Therefore, the decision was taken to use no movement joints throughout the 520m length of wall. Forces and bending moments were assessed for gross temperature effects including the possibility of local stress concentrations at openings. These were analysed by finite element techniques. Also internal stresses due to high early thermal hydration temperatures, climate temperature movements, creep and shrinkage for both permanent and temporary conditions were analysed.

The temporary condition, which proved to be the critical case, was assessed and reinforcement provided accordingly. In general terms the temperature control reinforcement was critical in lowly stressed areas while the applied load requirements dominated in the areas of the roses, and in the beam strips in slabs etc.

Once a sensible rationale had been developed for the structure the major task was not to produce large quantities of design calculations, but to effectively co-ordinate the various disciplines and control the geometry since the setting out of a very simple element could prove extremely complicated.

The reinforcement for this project was developed using the American standard detailing technique although in a slightly Anglicised form. Previous experience of this style of detailing had shown that its influence had to be fed into the design calculations at early stage. For example, by judicious choice of reinforcement and redistribution of moments a wide range of general arrangement conditions could be accommodated with a single detail. The tendency to let the detailing system result in over specification was monitored but tempered by the need for rationalisation in a building with few right angles.

## Building Services

### Climate

Riyadh, the capital of Saudi Arabia is situated 400km from the coast and 640m above sea level. It is characterised by very hot dry days with temperatures occasionally peaking at 50°C. Solar radiation is intense, 900–1000w/m<sup>2</sup>, and ground glare is harsh. Because of its inland desert location the resulting humidity levels are low and evaporation rates can be dramatic. At night the air

temperature drops sharply with back radiation from the ground to the clear night sky. The daily temperature swing is 20°C.

Local architecture has been dictated by the environment and the traditional building in Riyadh would be in courtyard form, with few windows in the exterior elevation. The walls would be massive mud block to protect the internal environment from the intense radiation and to reduce the cyclic impact of the heat when it eventually reaches the inner skin. The courtyard would be planned to provide shade and protection from the hot winds. In contrast to the domestic dwelling, the Bedouins utilised a light weight goat hair blanket for their travelling tent. This provided shade from the sun and was porous enough to allow air through for ventilation.

	Wall	Rose Structure
Heat transfer coefficient w/m <sup>2</sup> °C	0.6	2.6
Time lag	24 hours	1.0 hour
Shading coefficient	–	0.08

Table 1 Comparative Thermal Properties of Heavyweight and Lightweight Structures

As thermal barriers the fabric tents and the massive stone walls provide two extremes in thermal performance as shown in Table 1.

As a comparative indication of their thermal performance, the floor area of the lightweight structures approximates to 20% of the total area yet these structures represent approximately 45% of the installed cooling load.

### Services Engineering Design

The building has a gross floor area of approximately 24,000m<sup>2</sup> of which 20,000m<sup>2</sup> is air conditioned space. It is fully serviced to a high standard and reflects the high quality of internal environment which is demanded of modern day architecture in the Middle East. The architectural ambitions for the building were high. The design, however, presented the services engineering with a challenge both in the curved form of the plan and in the restricted building height to accommodate services distribution. The resulting virendeel beam satisfied all disciplines – services and structure could be accommodated on one plane, and the floor to floor dimension was kept to a minimum. Fig 12.11 shows how the services were distributed through the building.

By adopting this strategy a discipline was forced on the servicing which helped standardise details for services outlets in the ceiling (Fig 12.12). The limits on the height and width of the services which could be threaded through the openings also dictated that a number of smaller air distribution locations would be needed as a result of the limited lateral distributions possible. 35 air handling units plus 150 fan coil units were needed to serve the building supplying from 1m<sup>3</sup>/sec to 16m<sup>3</sup>/sec of air for the tents. This diversification of plant suited the wide range of activities catered for by the Club. Zone control was easier and more responsive to the required demand. It also provided a greater reliability for the total system. Air systems used are predominantly constant volume, variable temperature and all air handling units are fitted with coarse and fine filtration, steam humidification (electric generation), cooling and heating.

A major design problem was in handling fresh air intakes and exhausts to the plant rooms. Openings

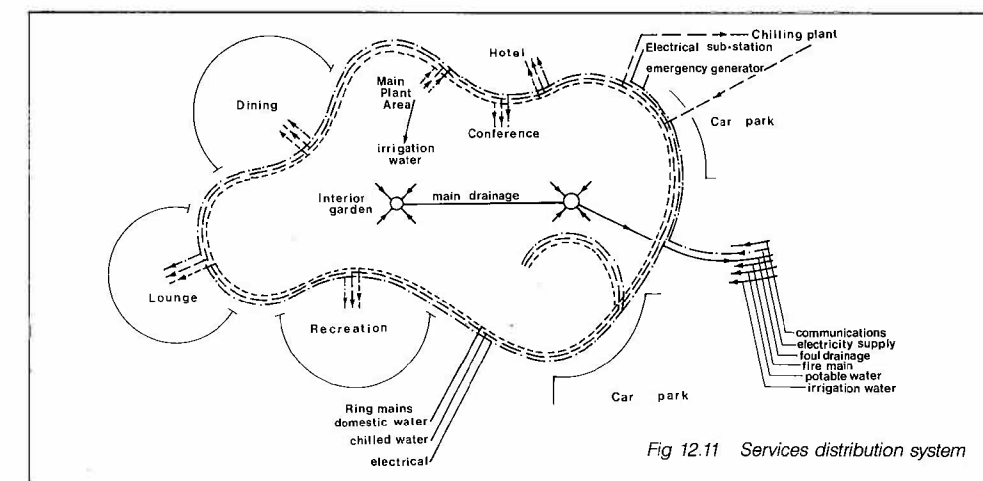

Fig 12.11 Services distribution system

It was recognised that a harmony between the wall and the delicate roses might be achieved by considering a form for the wall derived using tensile form-finding techniques. This used the Hookean concept that a hanging chain would define a pure compression form when inverted, deriving the natural path of compressive forces through the three-storey vaulted structure (Fig. 12.8).

Initially, ways of achieving such a pure vaulted structure were considered, using either a traditional masonry approach or that of precast framework. Engineering schemes were prepared for both and appraised in terms of constructability, cost and performance. Such vaults were found to be costly and time consuming to construct and offered insufficient space in the triangular voids at the springing points for service ducting. Nevertheless it was felt that the aesthetics of this study could be introduced effectively into the development of a more economic building structure which was also capable of resisting the large horizontal and overturning forces, induced by the rose structures. It would also be capable of incorporating a simple accessible service distribution system.

The walls consisted of 300mm of reinforced concrete, insulation and finally a layer of masonry cladding giving a total thickness of 600mm (Fig 12.9). The concrete beams and stubs used for the three highest levels of the wall were precast and designed to act compositely with the 150mm in-situ concrete slab. The exposed part of the beams was grit blasted to expose the aggregate and formed an integral part of the interior design. The result was a total structure and service depth of 650mm which contributed considerably to reducing the height or 'fort' like appearance of the wall. To meet the needs of a greater span and flexibility when the wall construction spread out into the more geometrically complex roses, a 325mm flat slab with columns was judged to be the most appropriate and mouldable form of construction.

The cable net roses facing the interior garden included a large uniformly distributed load into a concrete wall locally thickened to 450mm. The fabric roses on the outside of the wall applied a substantial point load towards the outside via the fan mast and anchorage arrangement.

The way the wall resisted these forces was redundant in character so a number of approaches were taken to assess possible structural actions. A simple cross-sectional study in conjunction with the earlier chain module was used to formulate a system of triangle of forces to minimise bending moments in the concrete frame (Fig 12.10). Local eccentricities in the force diagram were resisted by a full storey height shear wall between the top two levels. This structural action of shell and arch of the 300mm doubly curved R.C. walls and the 150mm

R.C. floors was an efficient configuration to resist the rose forces.

The nature and the geometry of the walls with the internal and external rose structures overlapping on each side of the wall did not allow a rational approach to be defined from which a system of expansion and contraction joints could be

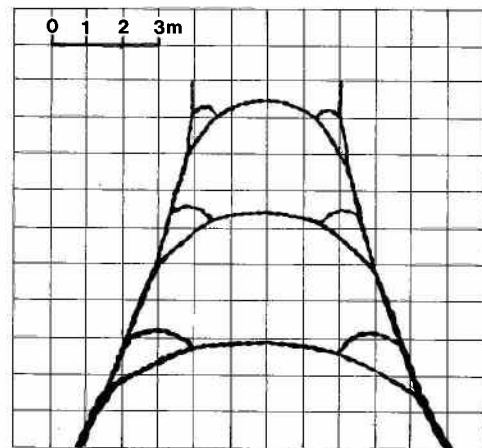

Fig 12.8 Hanging chain model for 'wall' structure

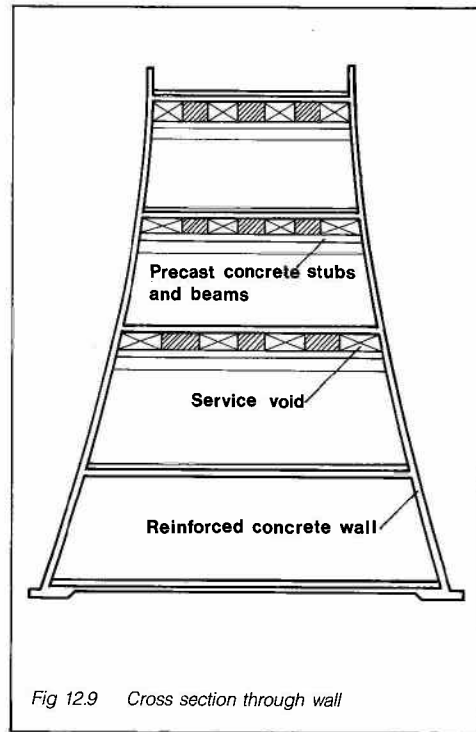

Fig 12.9 Cross section through wall

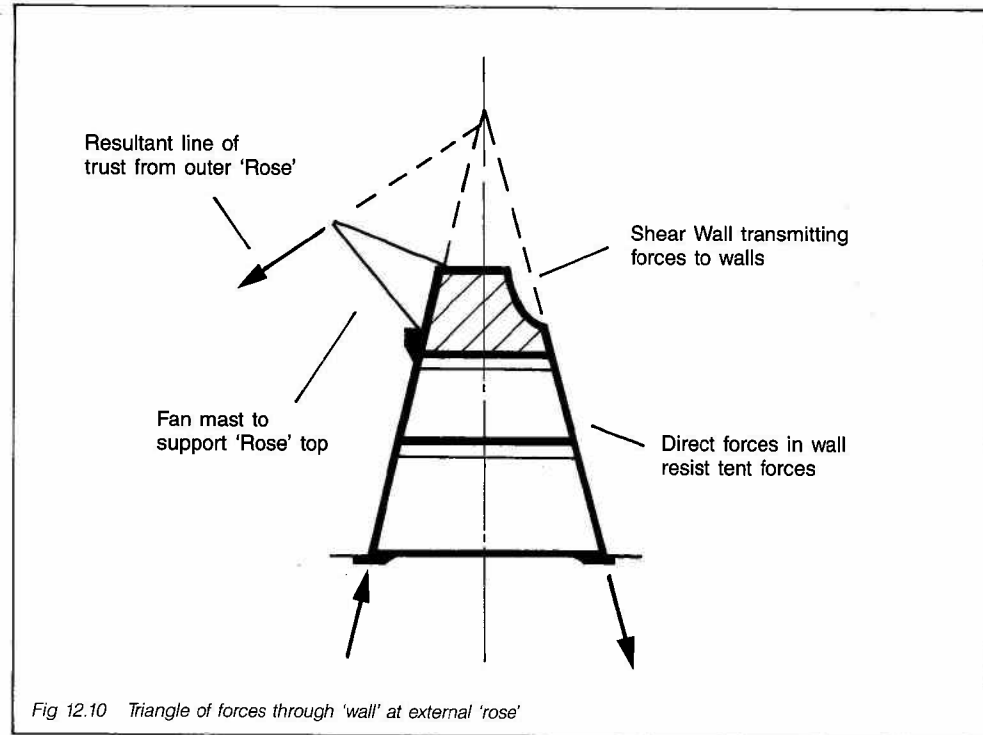

Fig 12.10 Triangle of forces through 'wall' at external 'rose'

approach. Subsequently he returned to New York to join with two other architect disciples of Frei Otto (Tod Dolland and Nicholas Goldsmith) to form Future Tents with whom we have done a whole range of tensile structures in the States and which also became the US outlet of Buro Happold.

Arnie Fullerton came over from Alberta with a delegation from the province to talk with Frei Otto and ourselves about covering the centre of a town at 58°N in the Athabasca shales area. Now just as structural engineering should be concerned with the most economic appropriate structure, services engineering is concerned with efficiency; the two disciplines interactively embrace the technical performance of buildings. One tends to study a building type broadly and the long span structures work had led to an increasing interest in building physics which in turn had led to the practice developing into building services work in the UK – which I am not allowed to write about – and overseas. This work was first led by Derek Croome, who left to become a consultant this year. The test is function and cost. We were into quantity surveying. All these were used in the design of the town enclosure at 58°N. Technically the most difficult problem was to evolve materials which would transmit enough of the spectrum of light; an innovative move of some importance.

We have carried out work on tensile roofs for many countries in the world and our form finding, analyses and cutting pattern programs are used worldwide. Among them are such projects overseas as the Harbour Theatre in Baltimore, Lever in Lille, an aviary for San Diego and pavilion for Sul'om Voe, a Wet 'n Wild for Las Vegas, advice on the Minneapolis stadium roof, helping Jan Bobrowski on the Calgary Saddle Dome and many others all of which led to an Institution of Structural Engineers' Special Award earlier this year.

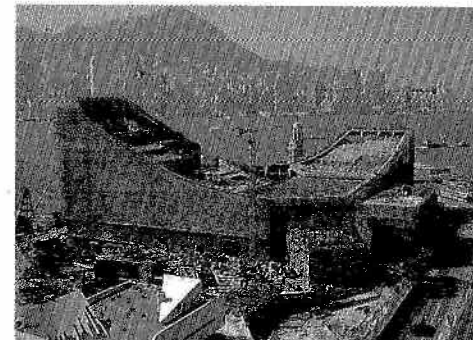

Fig 1.4 Tsim Sha Tsui Culture Centre, Hong Kong

Yet though flexible structures are of interest to many of us, and for which we are internationally well-known, they constitute a relatively small area of our work. Our main expertise is in providing an integrated solution to the great range of the engineering aspects of a design problem and, with good architects, in producing good buildings. We have developed expertise in such areas as environmental physics, fire engineering, construction analysis and project management, the design of temporary works, CAD, dynamics, geotechnics, as well as the full range of civil, services and structural engineering. Design competitions have helped us become better known. Some of us helped Sami Mousawi win the Mosque of Rome competition. We subsequently went on to design, and are now on site, with the Islamic Cultural Centre for Sarawak. Together with Michael Brawne we won the design for the National Museum of Archaeology in Amman. We helped Sheppard Robson win the Ibadan Exhibition Centre Competition and went on to work with them on a range of projects in Baghdad. The Diplomatic Club win led to a whole range of work for the RDS (now the ADA) in Riyadh and the current projects are the Grand Mosque, the Justice Palace and the King Abdul Aziz Cultural Centre in Riyadh.

This experience has led to other work and, on most of these projects we have supervised the construction as well as acting as consultants. The British Embassy in Riyadh (Fig 1.3) with Trevor Dannatt as architect, is a good example. Terry Ealey, and later Jerry Young, went to live in Kuwait and we have become consultants to the Al Marzook family, carrying out a wide range of tasks from proof checking to the engineering design of the Islamic Medical Centre. The family took us on into working in Cairo.



Fig 1.5 Kowloon Park redevelopment, Hong Kong

When the Government of Hong Kong held a competition for the design of the structure of the Tsim Sha Tsui Culture Centre, Buro Happold, in partnership with Tom Ho, won it against some of the most famous engineering practices in the world (Fig 1.4) and John Morrison, Eddie Pugh, Mike Cook and now Ian Leaper are among those who have lived there. We have continued to work there, the most recent projects being the Kowloon Park redevelopment (Fig 1.5) and now the Sensorama with Derek Walker Associates. The Ho Happold practice is now dividing but we shall remain in Hong Kong, hopefully continuing to do good work.

My mind reviews other countries, other projects. We have been involved in the design of over £2 billion of building work overseas in a decade. We have contributed more than £10 million in foreign exchange. Clearly they are all stories of personal relationships – people work with you and you with them because you both think you will perform better by putting your skills together – and because you think it will be fun. We have made opportunities for our fellow professionals – and they for us – and we have given opportunities for the rewards of travel to our own staff. It is not a bad record.

These are only our overseas successes; our record in the UK requires another story. It is the achievement of everyone in the practice, some no longer with us. Eddie Pugh has been with us since we started 11 years ago. Mick Green, Mike Shaw, Linde Hillier, Peter Cunningham and Bob Evans have been ten years with us; Peter Sherry, Ian Leaper, David Wakefield, Padraic Kelly and Tania Scotney nine; Ian Duncan eight years; and David Nash has looked after the geotechnics for eight years. Anna Morton and Barbara Blacknell have worked here for seven. Jerry Young, Barbara Towers and Geoff Werran have been here six years; Tony McLaughlin, Vincent Grant, Jon Bull, Glyn Trippick, Judith Smith, Paul Haskins – five years; Richard Gregory, Brian Cole, Marjorie Haley, Robin Clark, Ian Sutherland, Bob Campbell, Mark Jones, Martin Corbett and Mark Mitchell – four, and so on. But together with my partners and those who joined after, this Award is for all of you.

Edmund Happold

# Working Overseas – Organisation and Management

There is a need for far higher emphasis on the organisation and management of overseas engineering commissions, as compared to conventional commissions for work by consulting engineers in the UK. Depending upon the geographic location of the project, the approach to a commission in an overseas country will vary, but for the purpose of this article a generalized model will be considered.

## Obtaining the Commission

The strategy begins with the opportunity, be it a competition, a direct commission or an invitation to submit for a design. The first judgement must be one of deciding whether to respond positively or decline the opportunity. There is little point in expending time and effort if there is a low probability of success or the possibility that the finished commission will not be profitable or satisfactory. Having decided upon a positive response the outline framework of programme, budget and personnel is established. Often the precontract stage will be protracted and costly. The use of our own data base and experienced staff will reduce costs and, in the case of submissions previous work can be reviewed and plagiarized, so that substantial tracts of a submission can be assembled expediently. However, in the case of a competition considerable time is often spent synthesising the correct solution and presenting it clearly and concisely.

## Contract Preparation

Once a commission is offered it is common practice to be expected to prepare our own contract for the client's consideration. Overseas projects tend to be bespoke and the form of contract and the detailed clauses contained within it can have far greater importance during the execution of the design than is normal in the UK. The release of the fee is often linked with a study of the contract for compliance. All clauses are necessarily important in any contract but certain clauses have a higher profile than others. The most important are those dealing with the scope of work and terms of payment. Careful consideration of the detailed scope of work is imperative and cognizance of local and international customs for design and construction must be taken into account if the resulting design fee is to be acceptable. In this context the fabrication drawing contribution for all elements to be expected from the contractor is especially significant. Perhaps reinforcement detailing for all contract work will be undertaken by the contractor thereby relieving the consultant of a major tranch of detailed work effort.

## Fee Assessment

Once the detailed scope of work has been defined, the matter of corresponding fee and expense can be addressed. Ideally the scope of work can be subdivided into stages and each stage concluded with a defined list of presentation information often referred to as "deliverables". This list is important since it will form the reference point for payment of the fee appropriate to the stage. Each stage must be costed in man hours for the differing skills and grades of personnel to be employed. Numbers of reports, prints, and visits must be anticipated and costed. All of these costs are best prepared initially in sterling, although contractually will normally be expressed in the local currency. This factor leads to the evaluation of exchange rates. Fluctuating exchange rates alone can cause a well planned and executed project to be a financial disaster. Historical statistics and the basis of the currency be it US dollars, sterling, gold etc. are valuable tools in this judgement. At the end of the day it can only be a judgement, which must often be lived with for several years.

Having arrived at the required design fee and stages of payment the realities of negotiation must be considered as well as the unforeseen circumstances that will occur. The fee must be padded to reflect these costs as well as abnormal costs such as insurance, funding etc. Here our professional advisors are invaluable and consultation with bankers to arrange prefunding and the provision of performance bonds and guarantees, in parallel with insurers for protection against non payment or unfair calling of bonds, is an important task. The draft contract is assembled with the addition of clauses covering standards, units, language, copyright, law, disputes, suspension, termination, force majeure etc. and of course the programme. Simultaneous with these events must come the staffing resource planning. Design time is often very short and a well organized and structured office should not have the in-house resources to respond to the working drawing stage. Key personnel will have been identified and probably defined in the contract but temporary short term assistance via agencies is to be expected and researched in advance as well as the space and equipment to accommodate them. Their costs will be higher than our own and payment expected regularly and in advance of our receiving payment from the client therefore affecting cash flow projections.

## Contract Negotiation

Armed with a draft contract and the preplanning documentation we are in a position to visit the client and commence the contract negotiation. Upon arrival in a country new to our experience, unknowns including local taxation, insurance requirements, visa entitlement, joint venture arrangements, regulations, religious influences must be researched. The local embassy or consulate can be helpful in these matters and in any case it is wise to inform them of our presence and the purpose of the visit.

As the contract negotiations can be very frustrating, it is advisable that two principals are present to share the load – one to concentrate on the technical aspects and the other the administrative matters. Patience and compromise balanced with a polite firmness are necessary to overcome each impasse. Probably we will have the advantage of negotiating in our own language whereas the client and his advisors will be speaking in a language which is not necessarily their native tongue. Simple words avoiding the finer nuances of the English language will communicate far more effectively than a polished narrative. Once the contract is agreed, two copies should be prepared and signed, one for each party. Whatever the difficulties of negotiation, there is always an elation upon reaching a successful conclusion, and a desire to return home to give colleagues the good news and to celebrate. However there is useful work that can be effectively undertaken before departure. Having funded the expense of the airfare, advantage can be taken to collect basic data, make initial contacts with public bodies etc. The design process proper has started.

## Achieving "The Deliverables"

On returning to the office contract modifications must be communicated to colleagues and detailed resource planning undertaken. Bankers and insurers must be informed and immediate administrative matters attended to. The core design team must be assembled and briefed as to what is expected of them and the budgeted man hours for each contract stage discussed. Monitoring procedures are implemented and regular reviews undertaken. The goal at this stage is to achieve the first package of deliverables on time and secure the first stage payment. By choice this will have been predetermined as a relatively short period to

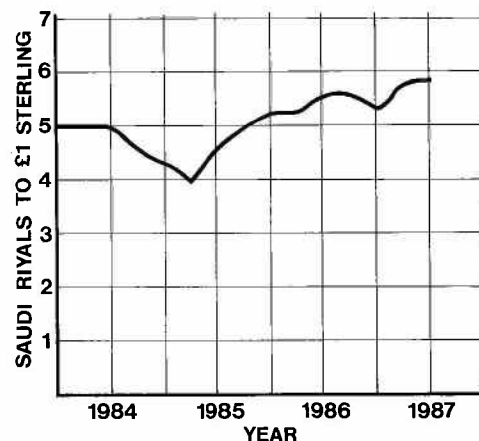

Fig 2.1 Fluctuation in Saudi Riyal exchange rate

enable the nature of client's response to be tested. An understanding of the client interests, decision making methods and specific demands upon the consultant will be invaluable for future stages when large quantities of documentation must be prepared. The process for collection of the stage fee will be tested and systems can be amended to suit the client's procedures.

Reasonable requests of the client for further clarification or modification of the schematic design at this stage are to be expected but within the context of the contract. Substantial modifications or extensions to the scope of work must be addressed at the time they occur and contract amendments agreed upon. Enthusiasm to respond to sensible modifications or enhancements without first amending the terms of our contract may result in dispute at a later date when payment for the additional work is requested.

The performance of any co-operating consultants must be reviewed. They have an obligation to permit our work to progress effectively and provide us with information on time and in sufficient detail to ensure confidence. We too have that same duty towards them. From this point the project pattern should be established and with regular reviews, advance planning, and regular client meetings to increase confidence and respect on both sides the project should proceed to a smooth conclusion. Inevitably there will be upsets from time to time – a war, an assassination, a coup, elections, an oil crisis, an indelicate television programme, the collapse of a currency, a strike, air traffic controllers' dispute, bankruptcy, holidays, staff leaving. As exporters we will try to cope. After all, they don't all happen at the same time even in the UK.

At the end of the project, release of the last 10% fee is often extremely hard to obtain and one wonders whether this is what journalists refer to as "invisible earnings".

For all that, exporting our skills is challenging, gives us engineering opportunities we would not otherwise have, and contributes to foreign exchange earnings. It further offers a chance to meet and discuss meaningful matters with people whose cultures, education and practice may be different to our own.

Peter Buckthorp

## Building Data

Site area	75 000m <sup>2</sup>
Built-up area	24 000m <sup>2</sup>
Total fabric area	3 900m <sup>2</sup>
Total cable net area	2 000m <sup>2</sup>
Total volume of concrete	21 000m <sup>3</sup>
Construction cost	SR 117M
(approx £24M @ average exchange rate)	

## Element & Breakdown of Construction Cost (%)

Substructure	4.63
Structural shell	20.61
Staircases	1.48
Doors and windows	5.19
Int partitions and doors	2.24
Internal finishes	7.89
Fittings and equipment	5.08
Furnishings	0.84
Conveying systems	1.09
Mechanical and plumbing	13.23
Electrical	11.32
Special construction	13.67
External works	12.73

tank within the club building itself. The treated effluent water is supplemented by the dosing with iodine and other nutrients to promote plant growth.

Each of the sub-areas are controlled by solenoid activated valves connected to the environmental management computer located in the building and can also be individually isolated without impairing the operation of the remainder of the system. A separate irrigation system connected to the fire ring main provides sprinkler irrigation to the grassed areas within the garden using potable water. Hand watering points are provided from the ring mains in the event of failure of the sub-systems; washout facilities to the ring mains are also provided to facilitate maintenance. The principal materials used for the piped irrigation system are either dense polyethyl or ABS (acrylonitrile butadiene styrene).

The approach road to the Diplomatic Club from the east is a single carriageway with paved shoulders, all in bituminous concrete construction. Chamfered kerbs denote the boundary of the trafficked highway with the footways on either side of the carriageway. The footways are of block paving construction. Initially bituminous concrete was specified for the car parking areas also but with an added red pigmentation. This proved difficult to achieve and the car parking areas were then constructed in concrete block paving. Within the garden zone hard areas are comprised of a variety of materials including block paving, Riyach stone paving and cobbled paving.

## Rose Structures

Both PVC coated polyester and PTFE coated glass cloth were considered for the fabric tents, the latter being chosen for its longer life span. Whilst PVC coated polyester cloth is easier to fabricate, damages less easily during handling and can accept greater tolerances in erection and patterning, the PVC degrades in ultra-violet light. The constituent materials of PTFE coated glass fibre cloth, however, are very stable and do not degrade with time, and so potentially have a long life, possibly 50 years or more compared with 10 to 20 years for PVC coated polyester cloth.

The fabric tent rose structures are fundamentally conical in form. They have radial supporting cables anchored via A-Frame steel masts to the ground at their perimeters, and by a top arrangement of masts to the top of the masonry wall construction via a fan mast (Fig 12.6). The fabric is attached at the bottom boundary to a cable spanning between the perimeter masts and at the top boundary to a cable spanning around the fan mast. The fabric is attached to the wall using clamping plates to a roped edge tied back with a rigging screw type connection to a short length of rail bolted to the wall.

Each of these cable net roses in the interior garden forms a single saddle surface spanning between the wall and perimeter masts. 14mm diameter cables at 500mm centres are used for the parallel grid net cables, with 44mm diameter cables for the boundaries. The boundary masts are detailed in a similar way to those on the fabric roses. The cable nets are covered with timber boarding, waterproofing, insulation, and clad with blue ceramic tiles.

The heart tent is of cable net construction, using 6mm stainless steel strand at 326mm centres (Fig 12.7). The boundary masts are tubular stainless steel tripods with a compression member and two ties. The 2020 painted and toughened glass tiles are attached to the cable net by stainless steel clips.

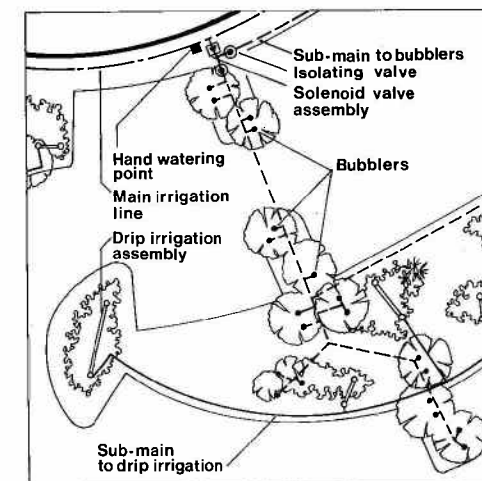

Fig 12.5 Detail of irrigation system

## Wall Structures

The concrete structure consists primarily of the wall which snakes its way around the interior garden and the two or three levels of accommodation over which the roses span. Much of the early scheme design was spent developing the form and construction of the wall to meet the varying architectural, structural and service requirements along its 520m length. In concept this was a very thick masonry wall – following the tradition of the local straw reinforced mudbrick buildings – and hollowed out to contain two or three storeys.

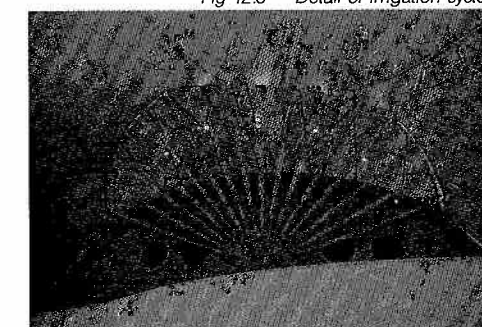

Fig 12.6 Fan mast to external 'rose'

Fig 12.7 Internal 'rose' and heart tent



<b>Project Data</b>	
<b>Client</b>	Bureau for the Project of Ministry of Foreign Affairs and Diplomatic Quarter Dr Mohamed Al Sheikh, Adul-Latif Al Sheikh, (planning), Ahmed Salloum (construction)
<b>Design team</b>	Omrana - Architects Frei Otto - Architects Buro Happold - Engineers
<b>Contractor</b>	Hanyang Corporation
<b>Specialist Fabric Contractor</b>	Stromeyer Ingenieurbau
<b>Date</b>	1986
<b>Cost</b>	SR 117m (approx £24m)

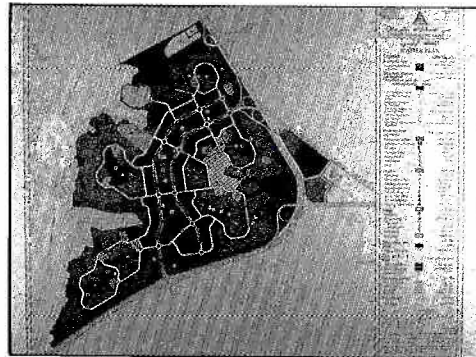

Fig 12.1 Plan of Diplomatic Quarter

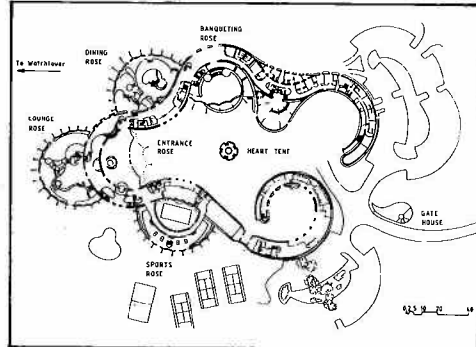

Fig 12.2 Site layout for Diplomatic Club



Fig 12.3 View of 'wall' and external 'roses'



Fig 12.4 Rock breaking equipment used on site

In 1975 the Government of Saudi Arabia decided to transfer the Ministry of Foreign Affairs to the capital city of Riyadh. As a result the Diplomatic Missions were also asked to establish themselves and operate from the capital city, in the Diplomatic Quarter, a new urban quarter on the north west perimeter of Riyadh. The Saudi Arabian government planned not only to provide the infrastructure for the area, schools, public service buildings, sporting facilities and landscaping, but also, as a gift to the Diplomatic Quarter, a Club for the use of diplomats, their families and guests (Figs 12.1, 12.2).

The scheme was initially conceived as a wall used as a unifying element between clusters of buildings, essentially traditional in character, enclosing a heavily landscaped interior garden. The 'wall' developed to become both wall and building, having heavy mass to control and even out temperature rises and falls, and containing those functions most continually used. Functions requiring large clear volumes, which were also more often than not to be used intermittently, were to be accommodated by lightweight long-span structures or 'roses' clinging to the heavy character of the wall (Fig 12.3). It was proposed to construct the wall using local stone and to construct the lightweight long-span structures as tents. The two tents facing the interior garden, for reception and banqueting purposes, would be of cable net construction with insulation and tile cladding, and would blend well with the intensive landscaping of the interior garden. They would also provide areas for formal functions which could be environmentally controlled with relative ease. The tents facing outwards towards the plateau, for sports, restaurant and lounge purposes, would be of translucent fabric construction, providing a sharp contrast with the massive wall in the desert landscape. These tents would be used for more informal functions requiring environmental control for intermittent and varied use.

Our involvement in the project comprised civil engineering and public health works, structural and building services design.

## Civil Engineering & Public Health Works

The four main aspects of civil engineering infrastructure are site preparation and levelling; drainage and irrigation; roads; and car parks and were carried out by the main contractor Hanyang.

The site preparation works involved the grouting of voids in the founding limestone together with the general profile preparation of the site itself. For the former a grid of small diameter bores was driven over the area of the club building and the vicinity

of the services compound; these were then pressure grouted to fill and seal all voids and cavities in the limestone structure.

General levelling was carried out by rock breakers (Fig 12.4) and rippers across the site for both the building itself and the external landscape areas, including those of the tennis court and swimming pool. The landscape work was carried out in close liaison with the landscape architects.

The drainage provision is for both foul and surface water disposal. Foul water is collected in the normal manner via water pipes and soil pipes and discharged into the foul drainage system either below ground floor slab or below basement slab level. Pipe materials for drainage are generally uPVC with some special sections in cast iron or clayware pipes. Manholes are constructed in concrete with special epoxy or bitumen linings to minimise sulphite corrosion.

Since there are several areas of deep basement requiring foul drainage servicing the overall system produces several deep excavations. Foul drainage from each zone of the Diplomatic Club is collected into a large pumping chamber below ground. This lifts the foul drainage discharge into the system installed for the Diplomatic Quarter to the east of the site. The wetwell to the foul drainage pumping chamber is sized to cater for a 24 hour breakdown without back-flooding into the piped sewer system, with alternate pumps operating at 3 times the maximum dry weather flow.

Surface water drainage is provided for the building itself, the gardens and other public areas, the car parks and the roads. For ground level areas the drainage is generally via conventional gullies into a piped sewer system. In some planted areas however, sub-soil drains are provided which then connect into the surface water drainage system via silt traps. Roof drainage from the club itself is via normal rain water down pipes connecting into the system, supplemented by overflow gargoyles catering for storm conditions discharging directly into the garden and other paved areas. The system was sized on the basis of a 50mm rainfall in a 20 minute period discharging away from the site via a piped system directly to the wadi surrounding the site to the north, west and south. Roads and car park drainage are augmented by ditch drainage beyond the paved surfaces provided for surcharge supplemental drainage to the gullies. All gullies to external road and paved areas are fitted with sand buckets to minimise silting up of the system.

A pressurised irrigation system is provided for the entire internal garden and planted external areas (Fig 12.5). For the internal and external areas separate irrigation ring mains are provided, fed by treated sewage effluent water from a main storage

<b>Project Data</b>	
<b>Building Area</b>	Approximately 250,000m <sup>2</sup>
<b>Owner</b>	Government of the Kingdom of Saudi Arabia
<b>Architects</b>	Büro Gutbrod/Frei Otto
<b>Civil &amp; Structural Engineers</b>	Buro Happold in joint venture with Ove Arup & Partners
<b>Services Engineers</b>	Schmidt Reuter
<b>Quantity Surveyors</b>	Widnell & Trollope
<b>Landscape Architects</b>	Büro Luz
<b>Contractor</b>	Miryung Construction Co Ltd (Initial Works)

Job No. 2, KOCOMMAS, was the project for the King's Office, Council of Ministers and Majlis Al Shura Central Government complex of the Kingdom of Saudi Arabia. The site for the project is in a prominent position in the north west sector of the city of Riyadh, and occupies an area of 1 sq km. It is adjacent to the newly established Diplomatic Quarter.

In September 1974 letters of requirements and functions for the King's private office and for the Council of Ministers building were given by the Ministry of Finance to Professor Rolf Gutbrod. During November 1974, when initial designs were presented to the Saudi Arabian government by Rolf Gutbrod, Hermann Kendel and Ted Happold, the design team were asked to add to the design a building for a Representatives' Assembly and Representatives' Offices. This assembly, known as the Majlis Al Shura, was not to be an elected legislative body, but rather an elected or nominated advisory body.

## Concept

Initially the site was to have been a smaller one, closer to the city centre, and adjacent to the Riyadh Hotel and Conference Centre. An agreement for the preliminary design of this major and prestigious project was signed at the end of July 1975 and interim architectural design reports were presented and accepted in February and May 1976. The design team was initially a joint venture of Büro Gutbrod and Ove Arup & Partners, supported by many specialist consultants, including amongst others, Frei Otto (lightweight structural forms), Schmidt Reuter (building services), Büro Luz (landscape) and Widnell & Trollope (quantity surveying). When Ted Happold and his partners established Buro Happold on 1st May 1976, the architects expressed the wish that Buro Happold and Ove Arup & Partners should jointly carry out the civil and structural engineering design work, and the joint venture was therefore enlarged to include Buro Happold.

Buro Happold undertook the civil and structural engineering design of the Council of Ministers Building, Representatives' Offices Building, shade structures, translucent marble facades and part of the initial works contract. In August 1976, when the final report for the preliminary design of the Council

of Ministers Building was presented, the government decided to change the site and asked the consultants to adapt the project to the new site in the north west sector of the city of Riyadh.

## Design

In January 1977 the masterplan report for the new site was presented together with the revised report for the preliminary design of the Council of Ministers building, and soon thereafter the government decided to proceed with the project and the design team were instructed to prepare construction drawings (Fig 3.1). In advance of completion of construction drawings for the main works, tenders were invited in 1979 for an initial works contract, comprising roads, central services unit, car parking, shade structures, staff villas and guards' barracks. An initial works contract was let to the successful tenderer, Miryung Construction. The contract was completed in 1983.

With the death of King Khaled, there followed a delay in proceeding with the main works. The government had for some time been unsure as to the extent to which a Majlis Al Shura should be established, and in the meantime King Fahd's palace was built on the adjacent site. The project was cancelled and the government proceeded with the construction on the site of an office complex for the King, being more an extension to the palace, and constructed by the same design and construct contractor who built the palace.

The design of the Council of Ministers building and Representatives' Offices building featured a translucent marble exterior facade to control heat and light gain into the buildings, and this was to be supported by a steel space frame and mullion system attached to the face of the buildings (Fig 3.2). A section of the translucent marble facade was built, as a mock-up, in the initial works contract. The office and administration areas were to be of concrete flat slab and beam and slab construction on an irregular grid layout, with basements set into the rock or fill areas. The roofs to the Council Chamber and central meeting and reception areas, and the floor of the Council Chamber itself, were to be of hexagonal grid steel construction, the form of which was determined by hanging chain models, such that when inverted the



Fig 3.1 Site model, KOCOMMAS

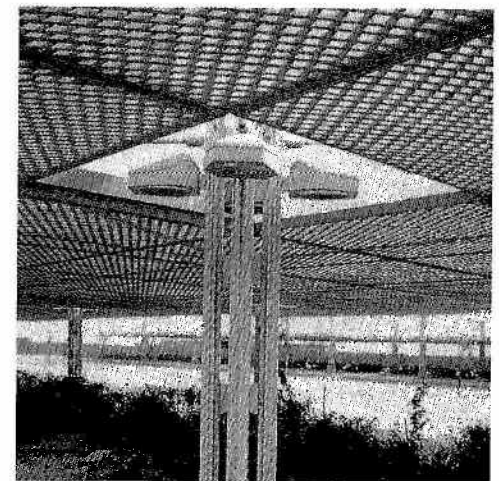

Fig 3.3 Aluminium shade structures

form would resist uniformly distributed loads in pure compression. These hexagonal grid steel structures were to be glazed and shaded by an array of aluminium louvres. An aluminium and timber umbrella structure system (Fig 3.3) was developed for use in shading of car parks, courtyards, inner facades and roofs. Extensive areas of these shade structures were actually built in the initial works contract.

This project was of major importance to the development of Buro Happold and was a key factor in the early growth of the practice. At some stages more than 30 engineers and draughtsmen were working from Gay Street on the project, a very significant number considering the size of the practice at that time.

Terry Ealey and Rod Macdonald

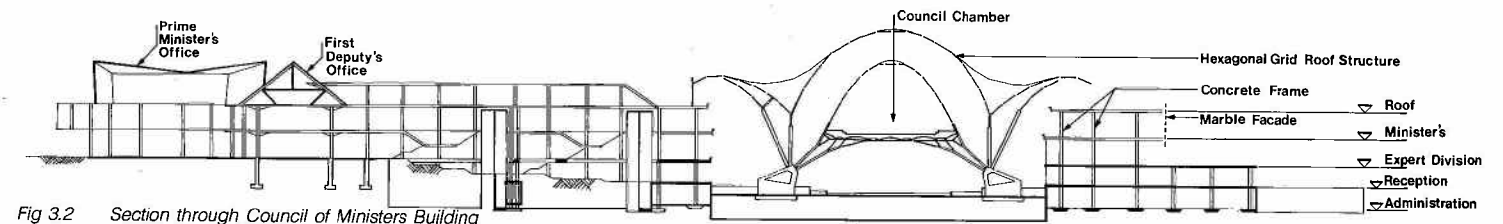

Fig 3.2 Section through Council of Ministers Building

## Project Data

<b>Client</b>	Bureau for the Diplomatic Quarter
<b>Architects</b>	Al Shathry
<b>Engineers</b>	Buro Happold
<b>Quantity Surveying</b>	Symonds-Tramor
<b>Consultants</b>	ACE Architects, Brussels
<b>Contractors</b>	CCC – Al Sarif
<b>Date</b>	1985
<b>Cost</b>	Approximately £5m (equivalent UK costs)

Engineers involved in buildings which are in any sense unconventional either in their use of materials or structural form, often face difficulties in securing the construction of these buildings at a reasonable cost. Whilst the engineer may be satisfied that his design is economical in its use of materials and capable of being assembled with minimum expenditure of labour and plant resources, this view may not be shared by the contractor who is tendering for the work. The contractor must be able to determine in advance the cost of the work. If he is unable to refer to existing data or to his previous experience of similar work, there is a considerable risk that he will quote a higher price to protect himself against unknown eventualities.

### Unconventional Structures

This problem is of particular significance with unconventional structures which are to be built overseas. Usually such contracts are tendered in open competition by both local and international firms and the opportunity for the engineer to liaise with the tendering contractor is limited.

Traditionally information given to contractors on drawings shows the finished condition of the building or structure erected in position. The contractor is responsible for the construction and therefore he has to satisfy himself as to methods of construction, temporary works and programme. To prepare his tender with confidence he must develop a complete understanding of the building within the limited period of a few weeks allowed for tendering.

### Method Statements

One method whereby contractors can be assisted in understanding the building in construction terms is by the engineer preparing a construction programme and method statement based upon his analysis of the construction process using his knowledge of the design. Method statements have been included in the contract documentation for a number of unconventional structures for which Buro Happold have been responsible. The procedure was used effectively for the new Sports Complex building at the King Abdul Aziz University, Jeddah. This building consists of a 9500 sq m cable net covering supported by eight masts with a clear span of 85m over the playing area.

A detailed analysis of the construction process was prepared (Fig 4.1) together with preliminary designs for the temporary works. The method statement was illustrated with sketches and included quantities of materials together with appropriate plant, equipment, and temporary works relevant to each stage of the construction. This document was included within the documentation given to the tenderers. The tenderers were informed that the methods defined within the statement represented

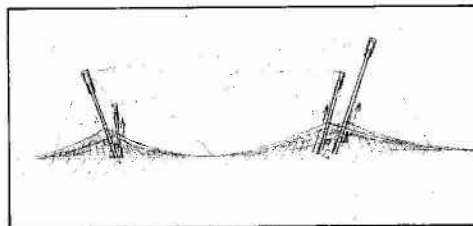

Fig 4.1 Typical form of method statement



Fig 4.2 Erection of cable net on site

one approach to how the work could be undertaken. They were informed that it would be their choice as to whether they used the method shown or any variation, or indeed any other method they preferred. It was however stipulated that in the event of the contractor wishing to use his own alternative method he was required to submit with his tender a method statement prepared in the same detail as that prepared by Buro Happold. Generally it has been found that most contractors will respond to a consultant's method statement by seeking to find either improvements and refinements or their own alternative.

On the Jeddah project the successful contractor for the erection of the cable net, a joint venture of Harbegg, a firm of Swiss structural engineers and Sarna, specialists in fabric structures, chose

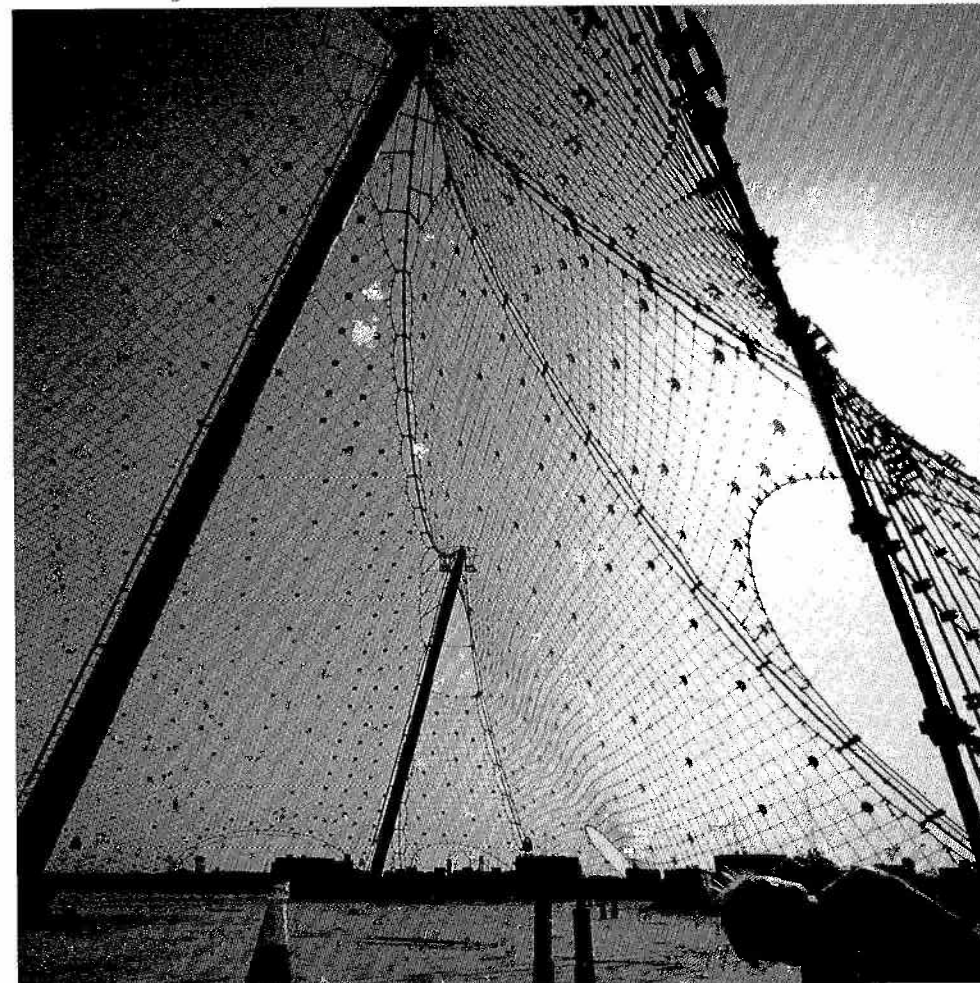

Fig 4.3 Completed cable net

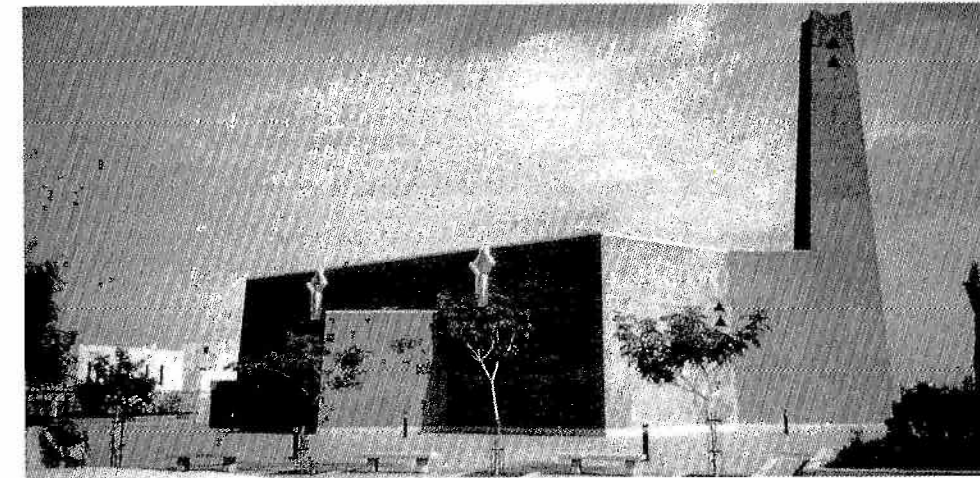

Fig 11.1 External elevation of mosque

Simplicity and austere are ageless qualities of the Najdi architectural traditions of the central region of Saudi Arabia, respect for which was an overriding objective for this project.

Architect Al Shathry was sympathetic to the objective – "There are many examples of religious buildings in which the worshippers are surrounded by acrobatic arches, impossible beams, incredible spans, dazzling skylights battling between themselves in a thunderstorm of forces and tensions, destroying the serenity and simplicity".

The architectural challenge of reconciling respect for traditional qualities with the demands of a modern fully engineered building was shared between the architect and ourselves as consulting structural and building services engineers (Fig 11.1).

### Architectural and Environmental Limitations

How to find an engineering solution which was appropriate to the technical requirements without destroying the simplicity of the traditional style? How to accommodate the high demands for controlling the harsh climate conditions whilst keeping the visual intrusion from ductwork to a minimum?

These problems were solved in a common fashion for all four mosques, which ranged in size from 400 to 1500 worshippers. The largest one, the Friday Mosque however controlled our design for structure and for environmental engineering.

The main problem was to find a means of satisfying the peak cooling demands which would occur only very infrequently. It was decided to exploit the capacity of the inner walls for storing coolness, and to handle the peak demands by running the air conditioning system to its full capacity.

Cool air was ducted through the deep cavity walls and emitted at high level to reach worshippers in the middle of the mosque. Low level extracts were concealed.

### Structural Solution

The structural solution relied upon a reinforced concrete frame with raking columns which received a marble clad block inner skin. Precast concrete planks with 40mm render were laid on the raking face of the frame to provide the weatherproof skin. The concrete roof was supported by internal columns which opened up to form a lantern structure providing diffused daylighting (Fig 11.2).

The design of these buildings demanded the highest level of co-operation and co-ordination between all the members of the design team. Our work started in 1982 and the four mosques were completed in 1985.

Ian Duncan

Fig 11.2 Internal support columns to roof





# Developments in Fabric Structures

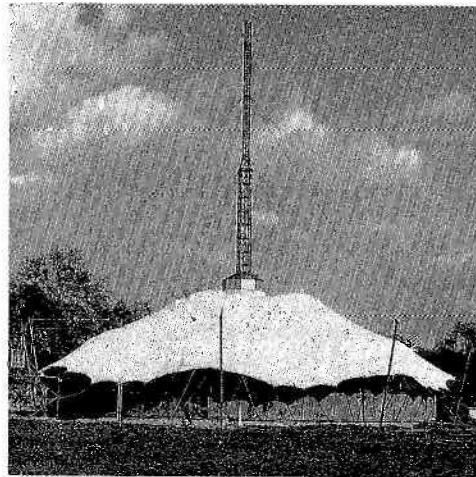

Fig 10.1 The Challenge to British Genius tent

In 1977 an exhibition was held in Battersea Park to mark the Queen's Jubilee. The architect, Theo Crosby, required a special 1,200m<sup>2</sup> circular tent with a high mast to be a landmark above the trees. At that time tent patterns were produced from physical models and the technology for numerically developing patterned tents did not exist. This design was therefore developed as a humped tent which used an initially flat sheet of woven canvas supported by external cables from a central mast (Fig 10.1).

## Patterning Programs

The geometry of even this structure was painstakingly developed from an accurate scale model. Clearly computers were the logical answer for numerically processing the free-form geometry of a tent and its individual components. Dr Michael Barnes of City University had already set up a program for analysing cable net structures using dynamic relaxation solution procedures. Chris Williams of Bath University provided an elegant way of modelling triangles to represent a fabric surface. David Wakefield who was studying under Michael Barnes joined us in 1978. He organised these ideas and set up the Tensyl suite of programs for the Hewlett Packard 9845 desk top computer.

The first project processed was the Baltimore Concert Pavilion in 1979 (Fig 10.2). At this time the program was only able to handle constant stresses though these could be different in warp and weft directions of the cloth. Patterning output was rather crude. Additional features were added as development work was stimulated by projects.

Improvements to programming included the ability to vary stresses included in each cloth and to smooth edges curves to seams and boundaries. The program also handles the full non-linear

analysis of structures with fabric, cable, rod and beam elements (Ref 1).

Errors in hand processing of boundary data and in cutting and welding in the fabrication are a constant irritation in the industry. Processing these details by computer helps to eliminate such errors. The patterning information now includes registration points along seam lines and work is in hand to fully automate the production of boundary information. The way is then open for feeding the data to automatic fabric cutting machines. The Tensyl suite is now being re-written and enhanced for an HP computer. It will include the facilities for colour graphics, interactive data inputting and stress review. These aspects of the work were previously those which took up considerable design office time and were often potential sources of error (Fig 10.3).

## Engineering Development

Along with the developments in computer processing, there have been developments in engineering standards, detailing and fabrication techniques to match the latest fabrics. The CFAN tent, 12,000m<sup>2</sup> on plan, featured tear stopping belts welded on to the membrane. The large teflon/glass tents for the prestigious Diplomatic Club in Riyadh contained improvements in detailing of the cable boundaries to take tangential forces, as did the arch supported roofs of the ADF Sports Hall at Jeddah.

Techniques using belt reinforcement of fabrics to take higher pressure loads were developed for fabric dams for the Rhein-Main Donau Canal and are now being used again for airship envelopes.

All the above improvements have contributed to our ability to handle the total design of a wide range of tensile constructions for permanent as well as temporary use (Fig 10.4). In 1986 the Institution of Structural Engineers presented a Special Award for innovation in this field to Buro Happold in recognition of this development.

## References

- 1 David Wakefield

Ian Liddell, David Wakefield and Mike Cook

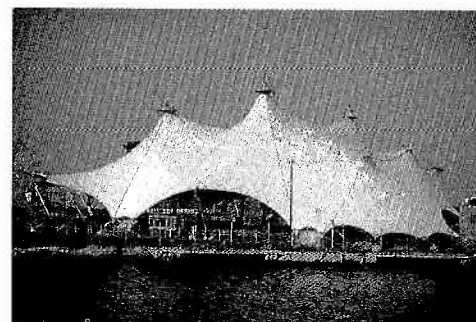
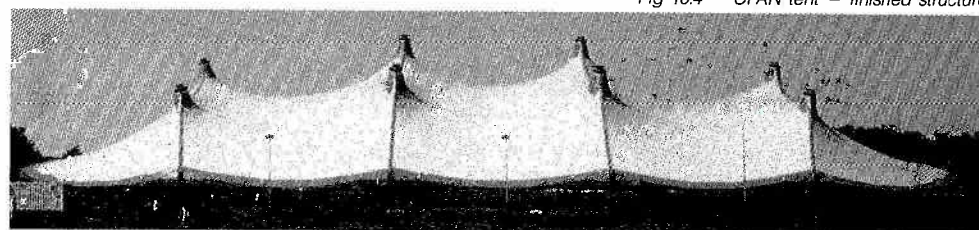

Fig 10.2 Baltimore Music Centre

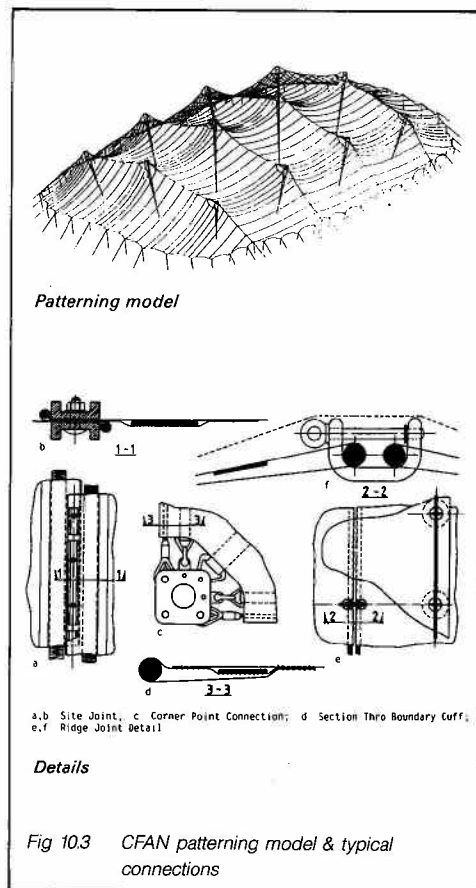

Fig 10.3 CFAN patterning model & typical connections

Fig 10.4 CFAN tent - finished structure

generally to follow the method statement prepared by Buro Happold but with a number of significant refinements, particularly in relation to the erection of the 30m main masts and lifting of the net from the masts. Eddie Pugh who had worked with Michael Dickson on the engineering design was the designated resident engineer for the cable net structure. He worked closely with Harbeggar during the period in which the final shop drawings were being prepared and the materials testing programme was under way.

## Cable Net Structures

Cable net structures are characterised by requiring long off-site lead-in periods for the manufacture and fabrication of materials with very short periods for on-site erection. When the building is situated in a distant overseas location it is essential that the components supplied to the site are accurately fabricated and packed and marked in such a way that the site assembly can proceed smoothly and quickly.

The cable net was assembled on site (Fig 4.2) from the preformed lengths of cable and joining clamps. The total period required for net assembly and hoisting into position ready for final tensioning was less than one month. The whole operation proceeded smoothly in accordance with the agreed method statement (Fig 4.3).

Method statements and construction programmes were also prepared for two cable net structures in the USA - the roof of the Ice Rink at Vail, Colorado (Fig 4.4) and the Gatlinburg Leisure Centre, Tennessee. In both of these instances Buro Happold had prepared cost estimations but the clients required early confirmation of cost from local contractors. The same procedures were again used to illustrate in each case a method of erection, supported by schedules of materials, labour and plant requirements. These were given to suitable specialist contractors who were asked to submit quotations for the structures within one week. As the timescale was minimal, dialogue meetings were arranged for the purpose of giving the contractors an opportunity to seek any further information they might require from Buro Happold concerning the design and erection methods, and for the engineers to examine the contractor's proposals to advise of any deficiency or overestimation. At the completion of these meetings the contractors submitted their firm proposals in terms of both cost and programme to enable the client to issue letters of intent for initial appointments.

The proposed aviary for the Munich Tierpark (Fig 4.5) presented unusual problems for the tendering contractors. The structure utilised materials in a unique manner. 4,500 sq m of landscaped area was enclosed to provide a free flight cage for large

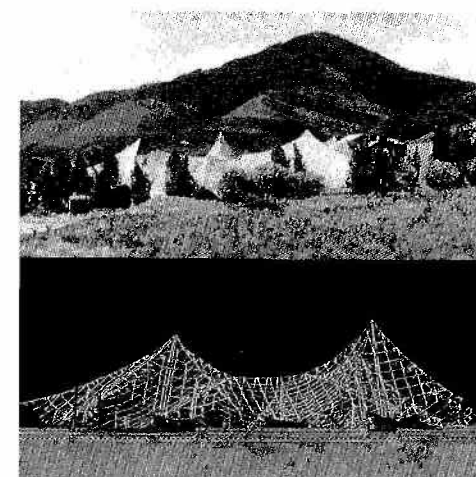

Fig 4.4 Model of hanging roof of Ice Rink, Vail, Colorado

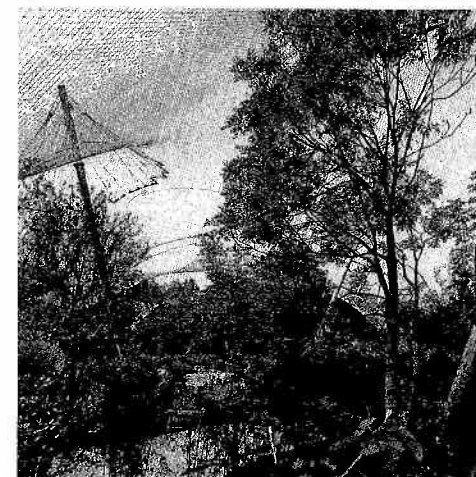

Fig 4.5 The aviary, Munich - completed structure

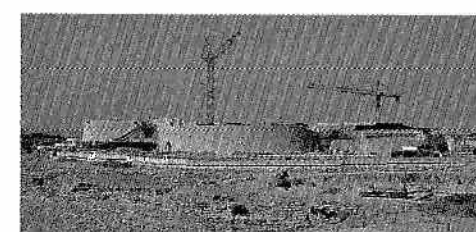

Fig 4.7 Construction of Diplomatic Club, Riyadh

birds of prey (Fig 4.6). The design consisted of a stainless steel woven wire mesh supported by tubular steel masts with the mesh clamped to a reinforced concrete boundary wall. Various methods for the fabrication of the enclosing mesh and its erection over the existing landscape, which included mature trees, were considered. To keep costs within reasonable limits Buro Happold were concerned to avoid excessive temporary works in the form of scaffold, stagings and access platforms. Particular attention had also to be given to the final stressing of the mesh in order to achieve the free form design.

Having established a suitable erection process which listed a detailed sequence of site activities, this information was combined with all offsite activities involving design, materials procurement, fabrication and delivery to site. The resulting programme was used to monitor all aspects of progress from final design to completion of the erection on site.

Similar techniques have been used to determine the critical aspects of the design and construction process for the Diplomatic Club (Fig 4.7) about which more is written later.

Rodger Webster

Fig 4.6 50m wide rolls of mesh used in aviary



# The Al Marzook Centre for Islamic Medicine, Kuwait

## Project Data

<b>Architect</b>	I E Zekaria Partnership
<b>Structural Engineers</b>	Buro Happold
<b>Local Consulting Office</b>	Arabi Engineers Office
<b>Building Services Engineers</b>	Jaros Brown and Bolles in association with MESC
<b>Quantity Surveyor</b>	D G Jones and Partners
<b>Civil Works Contractor</b>	Jassim and Siddiq Co
<b>HVAC Contractors</b>	Awali Trading and Contracting Co
<b>Electrical Contractor</b>	Farid Ibrahim Khalil
<b>Building Area</b>	11,000m <sup>2</sup>
<b>Opening Date</b>	1987

The Al Marzook Centre for Islamic Medicine was opened by Their Highnesses the Amir and Crown Prince of Kuwait earlier this year. The centre comprises a mosque for approximately 1800 worshippers, out patients clinic, laboratory facilities and library, together with management offices and a conference auditorium for the Islamic Organization for Medical Sciences.

The Islamic Organization for Medical Sciences is an international body engaged in the furthering of Islamic (homoeopathic) medicine, and was formed in Kuwait by Amiri Decree in 1984. However, the first steps towards establishing this Organization were taken some years before, when in 1978 Khalid Al Marzook and his brothers pledged their support and offered to build as a gift to Kuwait, not only a base with conference facilities for the Organization, but a public clinic, research laboratories and a major public mosque. The I.E. Zekaria Partnership was appointed as architects with Buro Happold as the structural engineers. The design was completed in 1980 and work began in 1982 on a site close to the existing Sabah Hospital.

## Development of the Scheme

The scheme was conceived as a series of colonnades forming a covered walkway between the mosque at one end, and the library, clinic and conference building at the other. The form of the colonnade was to be a vaulted arch; this and other related arch forms were adopted as a unifying element between the covered walkway and the buildings. Various means of achieving these forms were considered, from the use of marble or GRC cladding on simple concrete frames, to fair faced precast or insitu reinforced concrete. Whilst it could be argued that a cladding system would help to ensure quality of

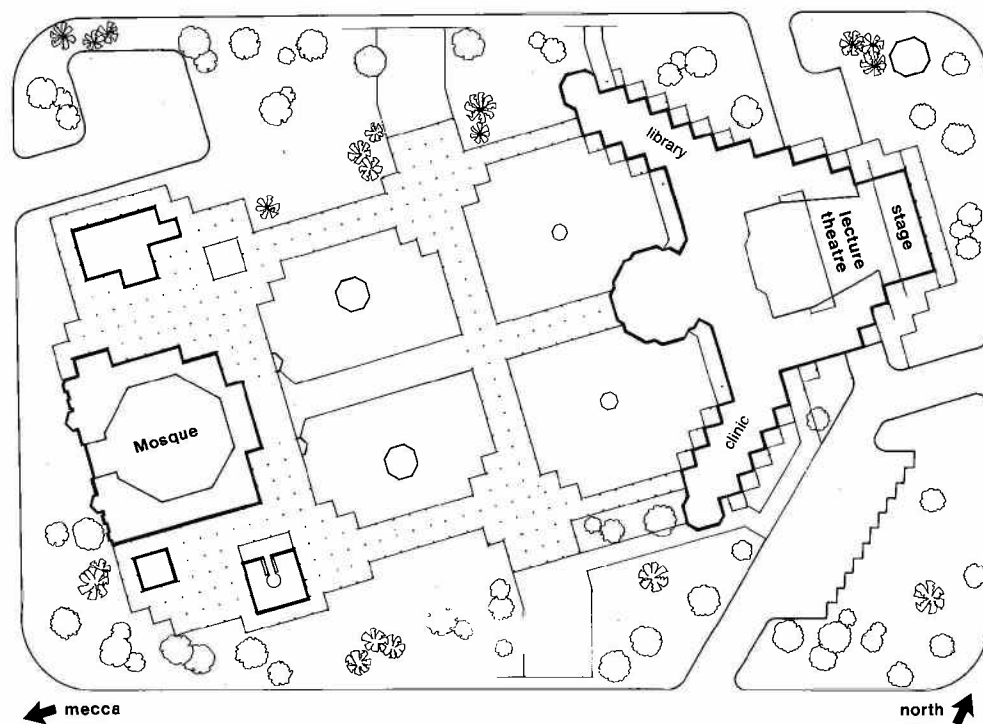

Fig 5.1 Site plan of Al Marzook Centre

finish, it would require details appropriate to cladding and the resulting aesthetic would not be that of loadbearing arch construction. The loadbearing aesthetic could best be achieved by the use of masonry, but the validity of building such complex arch and vault masonry construction nowadays, is doubtful even in a country where building stone is plentiful. There is no natural building stone in Kuwait and sufficient

skilled labour is not available, therefore concrete, either precast or in-situ, was considered to be the most appropriate material. Figure 5.1 shows the overall layout of the project with the colonnades linking the mosque and clinic together. The built area is 153m by 71m and Figure 5.2 shows the completed project from the north, while Figure 5.3 shows the detail of the colonnade.

Fig 5.2 The completed project, viewed from the north



on the ring beam and columns. When the roof is inflated these forces are relatively small.

## Cladding

Three options were considered for the combination of cable net and cladding:-

- 1) Teflon coated fibre glass cloth in panels 15m x 30m. The cables were 110mm diameter at 15m centres.
- 2) F.E.P. foil reinforced with grid weave glass fibre fabric in panels 6m wide supported by 60mm diameter cables on a 6m x 12m grid.
- 3) Double layer ETFE foil cushions in 1.5m wide strips supported by a 500mm x 500mm cable net consisting of two 16mm diameter cables in the short direction, and one 16mm diameter cable in the long direction.

Option 3 provided a nearly transparent roof which met the psychological requirements mentioned above and was preferred for that reason (Fig 9.4).

The weight of wire rope for all three options was approximately the same. However, the cost per kg of the heavier ropes was considerably more than the cost of the 16mm diameter rope. Similarly, the cost of the terminations and cable clamps was proportionally reduced. While there were many more fittings with the 500mm cable net, there was little difference in the total cost. The roll cost of the ETFE foil was about a quarter of the cost of the teflon coated fabric which, with the simpler installation procedures, more than balanced the extra edge jointing details.

## Performance in Use

Large low profile air supported roofs offer the most economical method of providing large areas of clear span roofs. Their shape is ideal for resisting wind forces. In cold locations the effects of snow loading need careful consideration and, like a machine, professional management and maintenance is necessary (Fig 9.5).

In a heavy snow storm, snow drifts into the valleys on the cable lines which, on existing stadium roofs with large fabric panels (Option A) are deep. This causes local ponding which potentially can initiate when the local snow load exceeds the internal air pressure. Once a pond is started, melt water and drifting snow will continue to run into it until it totally inverts. Once this happens, it is difficult and dangerous to clear it out and the whole roof may invert. The roofs are designed to carry the snow load in the inverted position so a major disaster does not occur. However, damage to panels can occur and they are expensive to replace. Panel inversion is avoided by shovelling, pumping, or

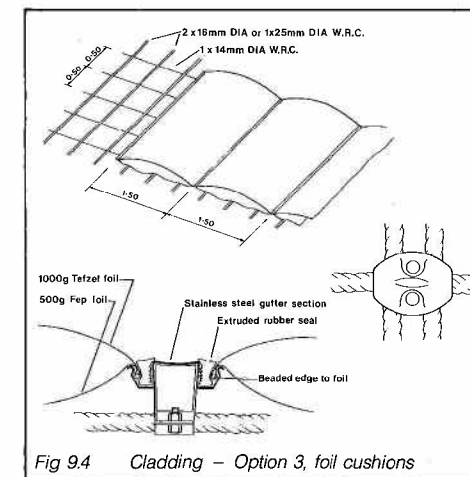

Fig 9.4 Cladding - Option 3, foil cushions

support the snow and wait for it to blow off or to melt off by solar heat gain to an interior space. One of the properties of the ETFE foil is that it allows radiant heat to be transmitted so even with two layers of foil, the radiant heat would melt the snow from beneath.

The incidence of local ponding could be eliminated by inflating the foil cushions above the internal air pressure. The internal pressure would be set at a level to prevent ponding of the whole roof. This is less than the maximum local snow load, .75 to 1.0kN/m<sup>2</sup> (3-4" water). To maintain these pressure levels, all the other elements of enclosure, cladding, ducts and fan rooms, and especially doors, had to be designed to operate satisfactorily at these pressures.

Fortunately the area where this building was to be sited in Northern Alberta is very cold and experiences low snow falls for most of the winter. Heavy falls only occur in the Spring and Autumn and then only occasionally so that periods when the internal pressures were raised would be infrequent.

## Design Team

For a project as diverse as this one, many people of different skills worked on different aspects of the project. In addition to the external consultants, those in Buro Happold who had some part in this unusual project were Ted Happold, Ian Liddell, Rodger Webster, Michael Dickson, Derek Croome, Gareth Jones, Mick Green, David Wakefield, Peter Moseley and Mike Cook.

Ian Liddell

most effectively by jetting the snow off the roof with fire hoses. The costs and danger of this snow clearing operation and the costs of repairing damaged panels have led to curtailment of the use of this economical form of construction.

Option 3 offers a number of advantages which considerably improve the resistance to ponding and facilitate maintenance and repair procedures.

For the Northern Township project, the enclosure was designed to span over the buildings below. When deflated, it was designed to hang clear of the buildings and to support snow loads in the down hanging position but it was clearly impossible to use cranes for repair. The 50mm cable net of Option 3 allows men to walk safely on the net for installation of the cladding and for repair of damaged panels. The panels themselves were quite small and it was considered possible to replace them with the roof inflated. Small cuts and tears could be repaired with adhesive tape.

Snow melt procedures using hot air were considered to be unreliable. An amazing amount of heat would be required and it seemed unlikely that this heat would get to the places where the snowdrifts were. Most of it would be lost directly to the air in the places where the roof was clear of snow. A better approach was to design the roof to

Fig 9.5 Elevation of structural model

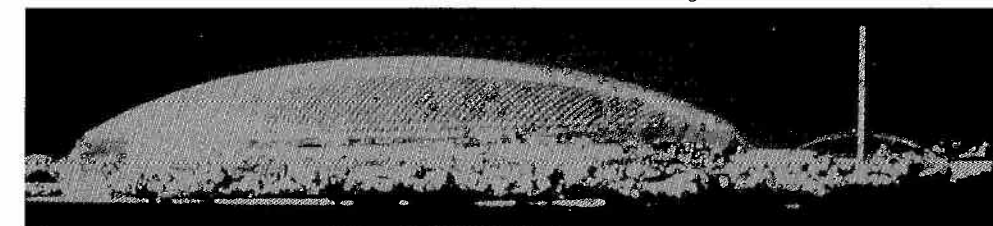

# A Covered Northern Township, Alberta

## Project Data

**Client** Ministry for Housing & Public Works, Alberta, Canada  
**Architects** Arni Fullerton, Frei Otto, Dennis Wilkinson  
**Engineers** Buro Happold  
**Quantity Surveyors** Ted Van Dyke  
**Consultants** Walter Bird, Birdair USA; Peter Stone, Michael Barnes, Martin Ansel\*, Peter Thoday\*, Martin Wilkinson\*, Derek Croome\*, Chris Williams\*  
**Area** 150,000m<sup>2</sup>  
**Date** 1981  
**Cost for enclosure and equipment** \$ Can 100 million  
 \*University of Bath

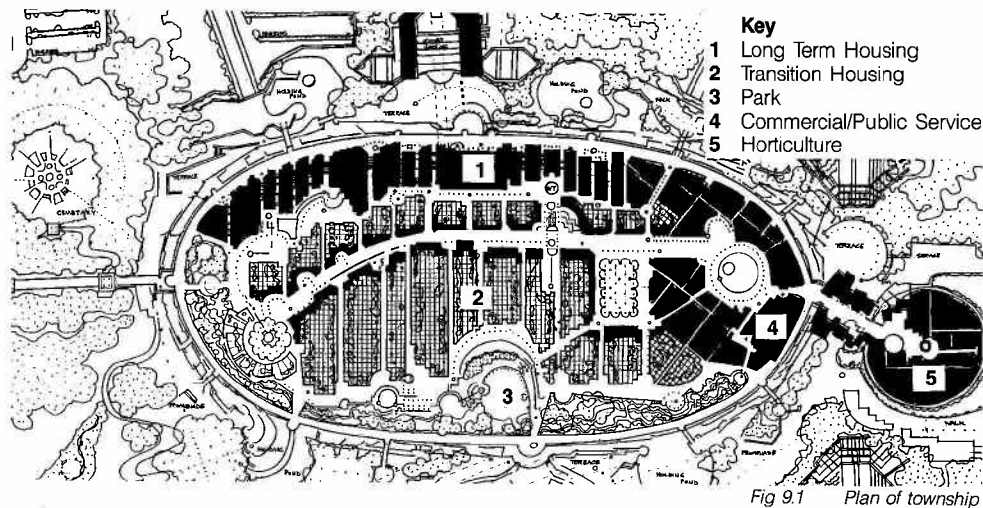

In 1980 Buro Happold were selected to join with the Canadian architect and planner Arni Fullerton, Dennis Wilkinson and Professor Frei Otto to prepare a feasibility study for a covered township on the Athabasca River in Northern Alberta. This project was generated by the planned expansion of tar sands extraction which was abandoned when the oil price fell in 1982. Two structural solutions were proposed by the team – one was a series of large cable net mast-supported structures each covering 3–4 acres and linked to the next unit. The other was a 35-acre air supported roof structure. Both these solutions were compared with more conventional proposals by another group for the problem of establishing northern communities containing family housing, apartments, a business and commercial district, schools and parks (Fig 9.1).

The study ran to five volumes of reports and covered all aspects of developing the new township including the psychological problems of working communities in extreme northern climates, the physiological effects of living in an environment cut off from natural light and air, and the technical problems of economic environmental control in an adverse climate, fire and smoke control within the enclosed space, and, not least, of constructing such a space. The study concluded that a large 35 acre air supported roof was best able to provide the suitable "free field" environment, and in effect move the internal microclimate of the township 10° of latitude south.

To meet the needs of the people living permanently within the enclosure, it was established that:—

- a) The roof should be as nearly transparent as possible so that the spectrum and flow of light should be similar to outside. Preferably the sky and the stars should be visible.

- b) There should be a clear view out towards the horizon on all sides, south to the sun and the park, north to the northern lights, east and west to the sunrise and sunset.

- c) The roof and supporting structure should be free from visual noise and disruptive elements of high contrast which would attract and disturb the eye.

- d) The internal space should be large enough to be a free field where the resident is no longer conscious of the enclosure in normal life. Coupled with this, the enclosure should give a feeling of protection from wind, cold in winter and heat in summer.

### Form of the Enclosure

It was felt that these requirements could best be met with a large air supported roof structure with glazed walls. The form of the building was developed so that the positive wind pressures impacted on the rigid glazed walls.

These sides were sloped to allow a smooth wind

Fig 9.2 Proposed N/S section through enclosure

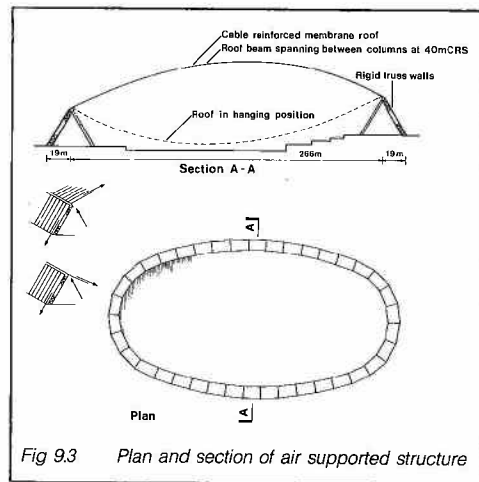
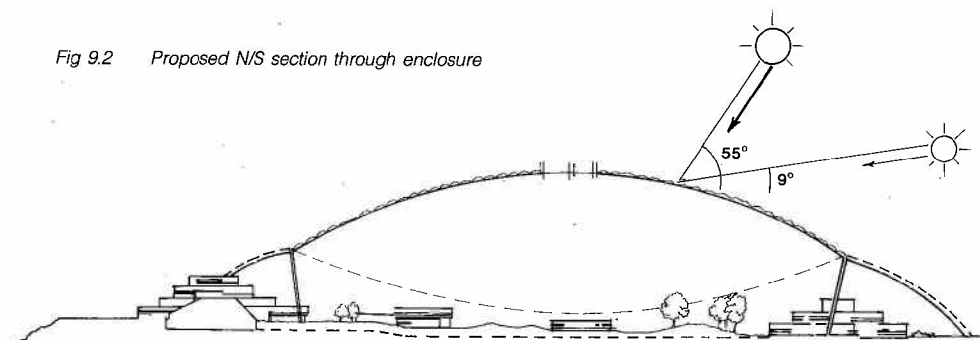

flow over the building. The plan of the building was elliptical with the long axis east-west. The buildings inside were arranged with the streets predominantly running north-south (Fig 9.2). The buildings were higher on the north side with car parking and service areas beneath.

### Structure

The roof was to be a cable reinforced membrane prestressed by internal air pressure. Uniform uplift loads are carried by increased tension in the cables. Down loads are carried by increasing the air pressure. Non-uniform loads are carried by the deformation of the pre-stressed surface.

The tensile forces from the roof are carried directly down the rigid sloping wall to the ground. Forces caused by the change of angle at the top of the wall are carried by the ring beam spanning onto the columns (Fig 9.3).

The ring beam is high enough to support the deflated roof clear of the ground. The roof must be able to support the full snow load in the down hanging position. This causes the maximum forces



Fig 5.3 Colonnades linking the mosque and clinic

One of the most interesting aspects of the design was the mosque prayer hall. The traditional problem for the design has always been the method of forming the transition between the square plan of the prayer hall to the circle of the dome above (Fig 5.4). The Gulpaygan Jami Mosque, built 1104, is a good example of how squinches were used to form the transition from square to octagon to circle. The materials available to the craftsmen of that time were brick and stone, yet their understanding of these materials led to beautiful multi-faceted squinches as they made the transition in the built form.

With the advent of reinforced concrete, designs in the Middle East suffered a loss of beauty which the traditional craftsmen had brought to the building industry. It became commonplace to introduce columns in the prayer hall to support the base of the dome, with the subsequent loss of quality of space. It was therefore our intention that with this design we would try and use the benefits of reinforced concrete extended to its limit, by computer analysis, to produce a column free prayer hall worthy of the old master builders.

Modern buildings require air conditioning, usually this is partly hidden on the flat roof around the mosque dome. It was decided to make a virtue of this necessity and create a plant room around the dome base. It was then possible to design the floor and roof of the plantroom as plates acting as tension and compression hoops with a raking inner wall which transformed the dome forces structure below. The raking support was finally decorated with the traditional mukannas.

The auditorium of the conference centre can seat 230 people and consists of folded plate floor slabs. The roof trusses are steel with spans of 21m supporting purlins and insulated metal decking.

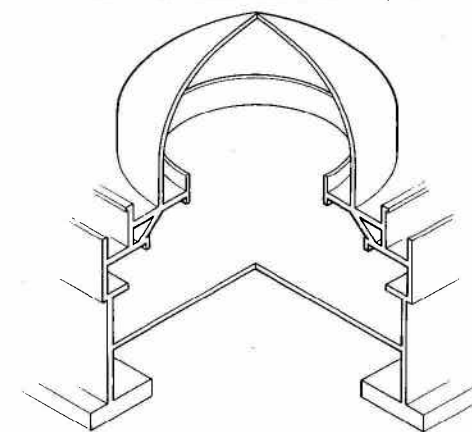

Fig 5.4 Isometric of mosque roof structure

Throughout the auditorium and clinic the floor slabs are waffle construction and where the soffits are exposed, purpose made octagonal waffles have been used to achieve Islamic patterns.

### Work on Site

The client, Mr Khalid Al Marzook, chose to manage the project, and the consultants were asked to provide supervision of the work. The first contract to be let was to Jassim and Siddiq Co, for concrete structure and blockwork. This company had no track record in major projects requiring fair faced concrete construction but stated their willingness and determination to achieve the high standard of workmanship demanded by the design. This would be no mean achievement since what was being demanded of them was a better standard of finished concrete than had been achieved to date in Kuwait. Precast concrete was considered and although suitable for the colonnade would not have been so appropriate

for the buildings, thus the contractor opted to construct all concrete works in-situ. As the foundation and ground works were nearing completion, the contractor made a sample colonnade element using locally made GRP shuttering. The standard of finish was not satisfactory and geometrical control proved to be difficult. The client then agreed to provide shutters to the contractor and a contract was let to Gillespie's in the UK to fabricate and supply steel shutter for all elements of exposed concrete. A programme for delivery of shutters in relation to sequence of work on site was agreed and since the colonnades represented a significant proportion of concrete work where there was a high degree of repetition, it was these shutters which were first to be made and delivered. An extremely high accuracy of shutter erection was necessary, in order to obtain a consistent width of joint, and generally the shutters were erected within a tolerance of 2mm. The resulting accuracy of the colonnade vault elements was almost always within 5mm.

At the design stage it was anticipated that the mosque dome would be cast in situ using a proprietary former method. For example Spirex Structures Inc have a system for forming domes of any shape in expanded polystyrene. This works by the use of a motorised cam at the centre of the dome with a telescopic arm which traverses the circumference of the dome delivering blocks of 100mm thick polystyrene which are heat bonded together in the form of an igloo. The motor and arm are controlled and the travel of the arm is pre-programmed to the required cross section of the dome. Reinforcement would then be fixed and the dome cast by the use of sprayed concrete. This system has the added advantage that it provides insulation, which is at the same time permanent formwork. The contractor elected, however, to cast the dome using conventional formwork and scaffolding. Templates were made for the dome cross-section and the contractor used these to accurately position the formwork supports. The dome was then clad with gilt ceramic tiles, as was the top of the 45m high minaret.

Hand made materials from many parts of the world were used in the finishes and decoration of the building, including tiles from Spain, mashrabiah and chandeliers from Egypt, carpets from east Asia, and internal cladding panels to the mosque dome from Britain. Many items were manufactured locally in Kuwait, including brass doors, teak doors and windows. The structure was substantially complete at the end of 1985 and the building was opened at the end of February 1987.

John Morrison & Terry Ealey

We have been involved in the civil and structural engineering design of five major building projects in Baghdad. These projects are: Fountain Square, a commercial development; Gaylani Education Centre, a centre for adult education; Villa Harathiya, a VIP guest house; and the Naish Khana development – all with architects Sheppard Robson; and the Karkh Cultural Centre with architect Rolf Gutbrod. Due to the war, only Villa Harathiya is under construction but the design content of all five projects is worthy of record. Two projects are outlined below.

However due to the war both these projects are presently held in abeyance.

### Project Data

**Client** Amanat al Assima, Baghdad  
**Architect** Sheppard Robson  
**Civil and Structural Engineers** Buro Happold  
**Mechanical and Electrical Engineers** J Roger Preston  
**Quantity Surveyors** Hanscomb Partnership  
**Floor area** 56,000m<sup>2</sup>  
**Construction value** £40,000,000

To further complicate the foundation design, the twin tunnels coming out of this new station pass under the variety store and the cinema. During the design, detailed discussions were held with the metro designers. It became evident that either project could proceed and be constructed before the other depending upon client's decisions. The building foundations were designed on the basis that the buildings would be built first and the metro later as this was seen to be the more onerous situation.

The hotel sits on piles 900mm in diameter and extending to some 24m below ground level, and the construction of the basement is complex in that the escalators for the metro entrance and the large ventilation ducts for the station pass under this building.

The variety store is also founded on piles 900mm in diameter, up to some 35m into ground. They are sleeved to 20m below ground level to reduce the effects of negative skin friction resulting from tunnel settlement.

The cinema building is founded on a 1m raft at basement level. Study showed that this raft could cope with the movements which were likely during the tunnel construction for the metro.

Initially, the brief required deep basements under a number of the buildings to provide car parking, plant rooms and archiving, and diaphragm walls were to be used for the construction of the basements in order to ensure cut-offs to water ingress during construction. However, as the design was rationalised, these basements were limited in most areas to one storey only, and the final design utilised sheet piling to allow the construction of watertight basements within.

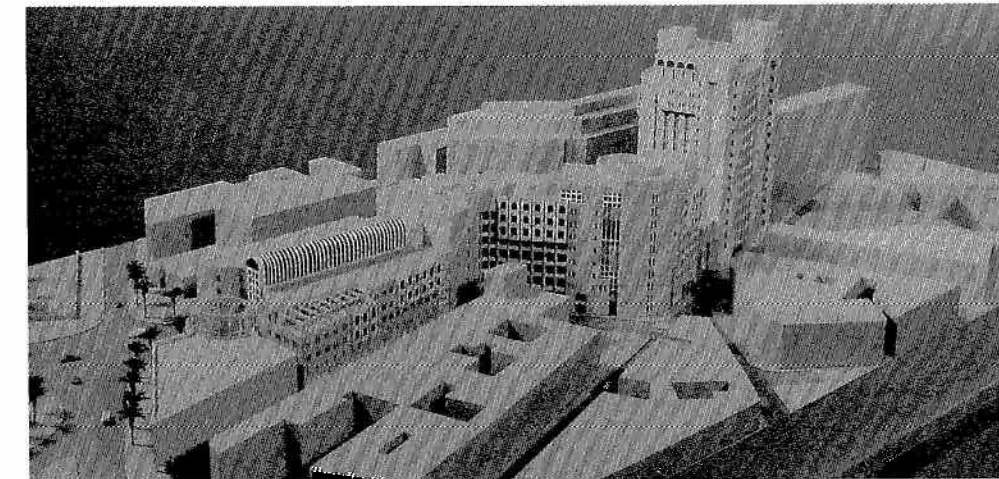

Fig 6.1 Artist's perspective of Fountain Square development

### Fountain Square, Baghdad

Fountain Square is a group of four buildings with a total floor area of 56,000m<sup>2</sup> (Fig 6.1). It is part of the re-development of Khulafa Street, one of the main commercial streets in Baghdad. The focal point of the development is a tower block 20 storeys in height, containing a 5-storey high banking hall rising from ground level with offices over, and a large roof-top restaurant. Adjacent to the tower block and separated from it by a ceremonial arch is a 10-storey 400-bed hotel which is S-shaped in plan with shops and a metro entrance at ground level. The third building continuing on from the hotel contains 4 floors of offices above 3 floors of variety store. The fourth building houses two cinemas with a total of 800 seats.

### Geotechnical Design

Information from earlier borehole records and from a site investigation carried out to Buro Happold's specification provided a profile of the sub-soil conditions. The site is overlain to a depth of 3–7m with made ground. Beneath this is some 5–10m of stiff, brown silty clay with sand, and beneath this again is medium dense sand interbedded with stiff silty clay eventually becoming dense, fine and medium sand. The ground water table is understood to vary from 1–3m below ground level.

Prior to our appointment, work had started and ceased on a new building on the tower block site. 900mm diameter piles – claimed to be 20m long – had been installed in the site at close spacing. Over much of the site it was not possible to pile between these existing piles and it was established that to remove them would be very difficult and costly. Integrity tests were carried out on the piles and a procedure for load testing them was defined.

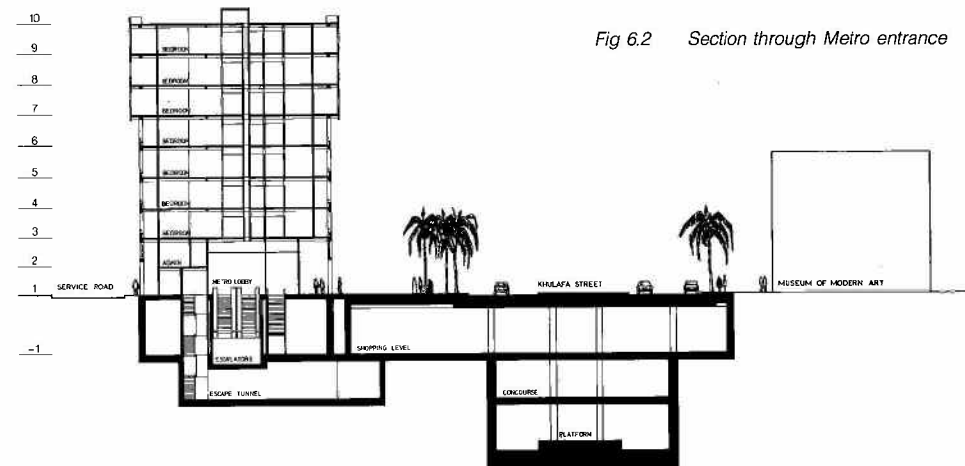

Fig 6.2 Section through Metro entrance

### Project Data

**Client** Kingdom of Saudi Arabia  
 Air Defence Force  
**Architect** ACE, Riyadh; SRZ, Brussels;  
 Krikor Bayarian & Associates, London  
 Buro Happold  
**Civil & Structural Engineers** Ferguson & Partners, Bristol  
**M & E Engineers** Symonds Tramor  
**Quantity Surveyors** OCC Weavers Ltd  
**Main Contractor**

The sports centre is part of an extensive long term redevelopment programme which is currently in progress at the ADF base on the coast of the Red Sea in Jeddah.

May 1984 and the project was completed in early 1986.

### The Stadium

The site allocated for the sport facilities measures approximately 400m x 300m and is surrounded by existing site roads which form part of the base infrastructure. The brief for the new sports centre was for the provision of Olympic style sports facilities and was to include: a 50m swimming pool, large and small sports gymnasia for court games, judo, table tennis, etc, a 50m rifle range, external playing courts, a 400m running track and playing area for field events, and a football pitch with shaded spectator seating for 10,000 people.

The design of the original 10,000 seat grandstand was carried out at the same time as the multisports building and comprised stepped spectator seating located adjacent to the finishing straight of the athletics track (Fig 8.2). Seating was massed about the centreline of the football field with reducing capacity towards the ends. The structure comprised in-situ concrete raker frames at 14m centres supporting precast tee shaped seating units. The grandstand was orientated with the back towards the setting sun to allow for afternoon and early evening use and provided shade by means of an open lattice roof supported on tubular steel roof trusses. To provide unrestricted sight lines the steel trusses were designed to cantilever from the support columns at the rear of the main raker frames – a distance of some 36m (Fig 8.3).

Shortly after the start of the construction of the multisports hall a decision was taken by the client to increase the capacity of the spectator seating from 10,000 to 25,000 by extending the grandstand structure into a stadium which would entirely enclose the running track, sports field and football pitch.

Many of the features of the original grandstand design were liked by the client, in particular the long span cantilever roof structure, and were to be retained in the stadium design.

However, extensive modifications were required to suit the revised circulation and egress requirements of the stadium. Certain structural modifications such as the extensive use of precast concrete were introduced to suit the contractor's preferred method of construction.

By November 1984 the replanning studies were complete and work started on the detailed design and production of construction information for the new structure (Fig 8.4).

Work started on the stadium construction in April 1985 and the entire project was successfully completed in Spring 1987.

Brian Cole and Ian Liddell

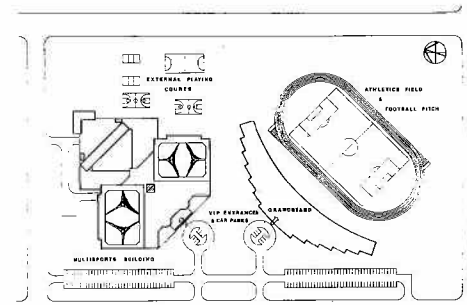

Fig 8.1 Site plan of original project

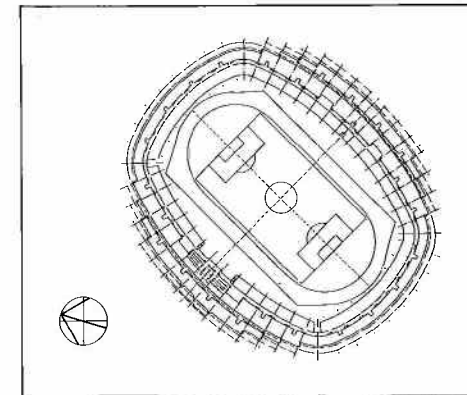

Fig 8.2 Plan of 25,000 seat stadium

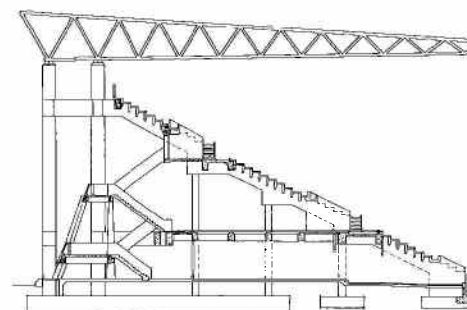

Fig 8.3 Section through stadium

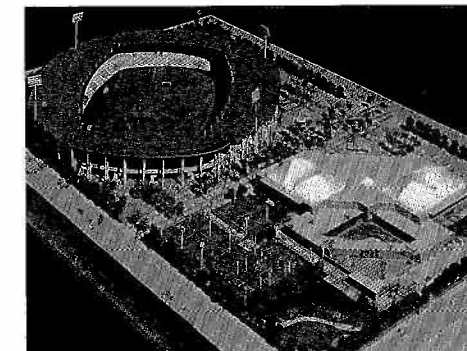

Fig 8.4 Model of completed project

### The Design Concept

The original design concept was for two major buildings: a multisports hall located on the northern half of the site and comprising the swimming pool enclosure, a major sports hall, minor sports rooms, changing facilities, etc; and a large grandstand structure located to the north west side of an athletics track and football field, which was positioned on the southern half of the site (Fig 8.1). External playing courts were located adjacent to the multisports building and both the sports building and the grandstand structure contained VIP reception suites, foyer areas and changing rooms.

### The Multisports Building

The multisports building is air conditioned throughout and is constructed of in-situ and precast reinforced concrete. It is essentially cruciform in plan with the swimming pool enclosure and the large sports hall positioned at right angles to each other with a large two storey entrance foyer located between. Tribune seating and bleachers are located along the long sides of the main halls with access from the first floor off the entrance area. Minor sports halls and changing rooms are positioned along the other two arms of the plan cross with the 50m rifle range linking the ends of these areas.

The long span roofs to the swimming pool and main sports hall measure 60m x 40m in plan and comprise teflon coated glass fibre membranes supported on box section tripod arch support structures. The steelwork arches also support suspended lighting pods and an inner membrane ceiling. Access gantries to the lighting pods are contained between the two membranes. The resulting translucent roofs enable the main sports halls to be used during daylight hours without artificial lighting.

Design work started on this project in 1983 and was completed by the end of that year. Construction of the multisports hall started on site in

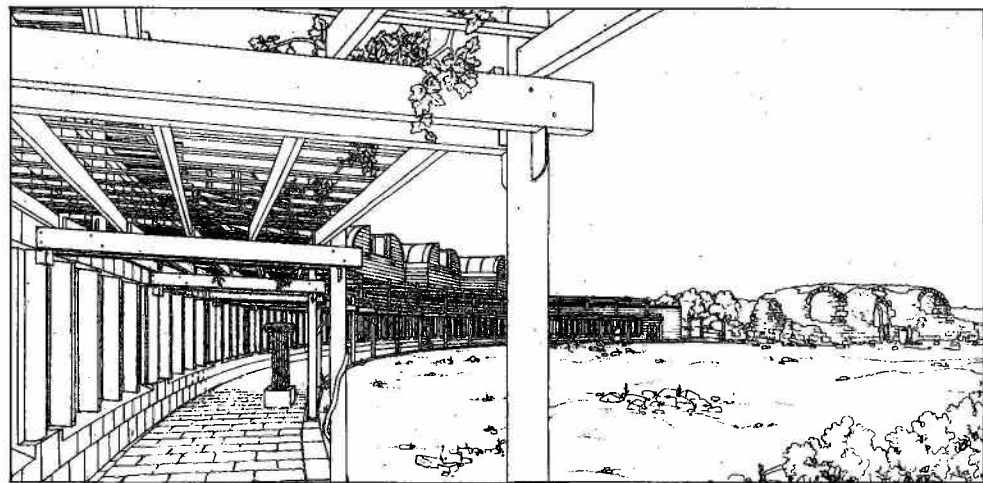

Fig 7.3 Perspective from walkway to Umayyad Palace

The eight galleries containing exhibits from the Stone Age to the Islamic Age are entered off the semi circular walkway with views across to the Umayyad Palace (Fig 7.3). These are of massive reinforced concrete vaulted construction with massive stone and blockwork walls. The shading to the vaults allows penetration of low angle winter sun but excludes direct high angle summer sun while admitting diffuse natural light into the gallery spaces themselves (Fig 7.4). Optimisation of this system by Martin Wilkinson, University of Bath, is achieved by modelling the galleries under an artificial sky.

To minimise the disturbance to future archaeological work beneath the galleries a structural table (C) was created at main gallery floor level and all the loads transferred by 1,000mm x 600mm cross beams to 800mm reinforced concrete piers on mass concrete foundations at bedrock on a 6.25 x 5m grid. Penetration of the gallery slab between the cross beams to view excavations and recess exhibits was therefore possible through the 250mm floor slab. Expansion joints are provided between galleries 2 and 3, and 5 and 6 in the superstructure. Lateral and longitudinal stability of the structure is obtained by the reinforced concrete portal frames supporting the intermediate storage pod structures and vaulted roof on 400mm diameter columns. External walls are of dressed 100mm stone skin and 200mm blockwork and the internal walls are 200mm solid block walls divided into 6.25m maximum wide panels and tied to the reinforced concrete frame structures within the ventilation cavity to ensure stability in an earthquake.

#### Internal Environment

From an environmental point of view the building construction was designed to have sufficient mass

to reduce the servicing energy input by making maximum use of the building envelope as a climate moderator, with windows in the sunny part of the building being minimised and shaded. Lengthy energy studies were carried out to optimise this thermal response by Derek Croome and Gareth Jones.

In winter sufficient heat is provided via polypropylene hot water coils (D2) located in the sand beneath the marble floor. This acts as a low temperature radiant panel and is supplemented by a small quantity of warm to fresh air at high level sufficient to satisfy the maximum expected occupation. A sense of warmth is clearly noticeable to visitors, with the heated surfaces at floor level providing an environment which is thermally comfortable and which provides a temperature gradient warmer at foot level than at the head.

In summer, maximum advantage is taken of the 8°C diurnal temperature range operating on the thermal mass of the building to minimise the peaks and variations of internal temperature. Windows are minimised and are shaded. This is achieved at night by drawing down cool air via the ventilated wall cavity into the undercroft (Fig 7.4) and then into the interior of the galleries (B) and by circulating cool water through the floor panels (D) to reduce radiant temperature. During the day heat

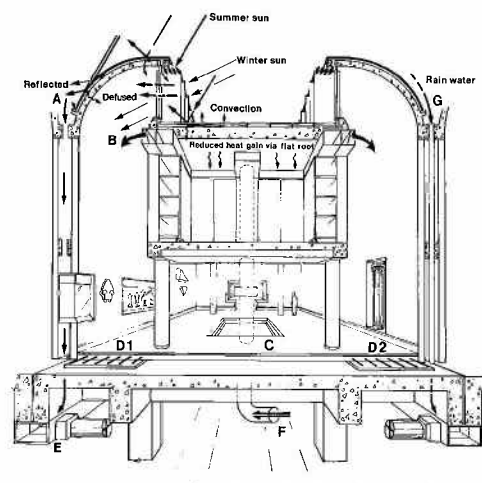

Fig 7.4 Section through a gallery

gains are then offset by the stored coolth in the massive structure. Air supply via the cool undercroft is from a high level in the gallery sufficient to satisfy occupancy leaks and is pressurised to ensure natural leakage to the outside and exclusion of dust.

Such a construction system offers the possibility of a modulated facade of stone work stabilised against various loadings and evocative of surrounding constructions (Fig 7.5). It also provides in the galleries a naturally tempered environment in which a flexible layout of exhibition space for both large and small objects can be achieved.

This was an enjoyable and constructive collaboration between Michael Brawne Assoc, Arabtec and ourselves. It is only a pity that pressures in the Middle East have so far prevented its execution.

#### References

- 1 The Antiquities of Jordan. G Lancaster-Harding.
- 2 Earthquake Risks in Jordan. P L Evans. BRE.

Michael Dickson and Mike Shaw

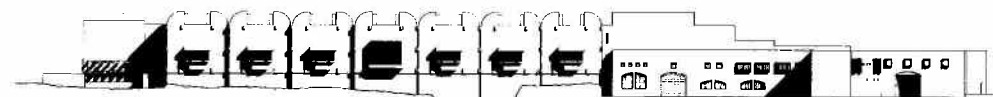

Fig 7.5 Western elevation of museum

#### Basements as Shelters

The brief also required that the basements be designed as shelters capable of providing protection from a "near-miss 250kg bomb". Calculations showed that to resist such forces with reinforced concrete working in bending would result in very large structural elements. However, a study of the shockwave pattern resulting from such an explosion demonstrated that the momentum gained during the early positive pressure wave approximately balances the momentum lost in the later pressure wave. It was possible to demonstrate that an unrestrained mass equivalent to a 400mm concrete slab would move about 6mm and come to rest under the forces resulting from the explosion. The structure and, in particular, the detail around the columns was designed to work in this way.

#### Structural Design

Baghdad lies in an area which suffers from seismic activity. Earthquake data was collected from the Global Seismology Unit at the United Kingdom Institute of Geological Sciences. Data was available to various magnitudes from the year 1900. This data was analysed and a decision reached to classify the severity of the seismic activity as equivalent to Zone 1 in the USA Uniform Building Code.

The superstructure of the tower consists of the two concrete cores in opposite corners of the square plan to provide good restraint against possible torsional effects from seismic forces (Fig 6.3a,b). They are designed to be constructed using either slip form or climbing form methods. The remainder of the superstructure is a structural steel frame taking its stability from the concrete towers, the beams working compositely with the metal deck and in-situ concrete floor construction.

Wind data was obtained from the London Meteorological Office in order to establish a 50-year design wind speed of 40m/sec for a 3-second gust.

The static requirements of the Uniform Building Code were used for the buildings in general and the tower block was analysed in addition by representing it as a free cantilever with its own associated mass per unit length. Rules were established for the movement joints between buildings and for the detailing of the non-structural elements such as suspended ceilings, windows, cladding and partitions.

The stability of the variety store and the offices above is provided by a structural steel frame on a column grid of approximately 6.5m x 8.5m. The floor beams are designed as stub girders with the secondary beams sitting over the lower member of the stub girder to provide space for the air conditioning ducts, etc.

The superstructure for the cinema is in-situ reinforced concrete with grillages of beams following the radial and circumferential grids to provide the stepped floors required for the auditoria.

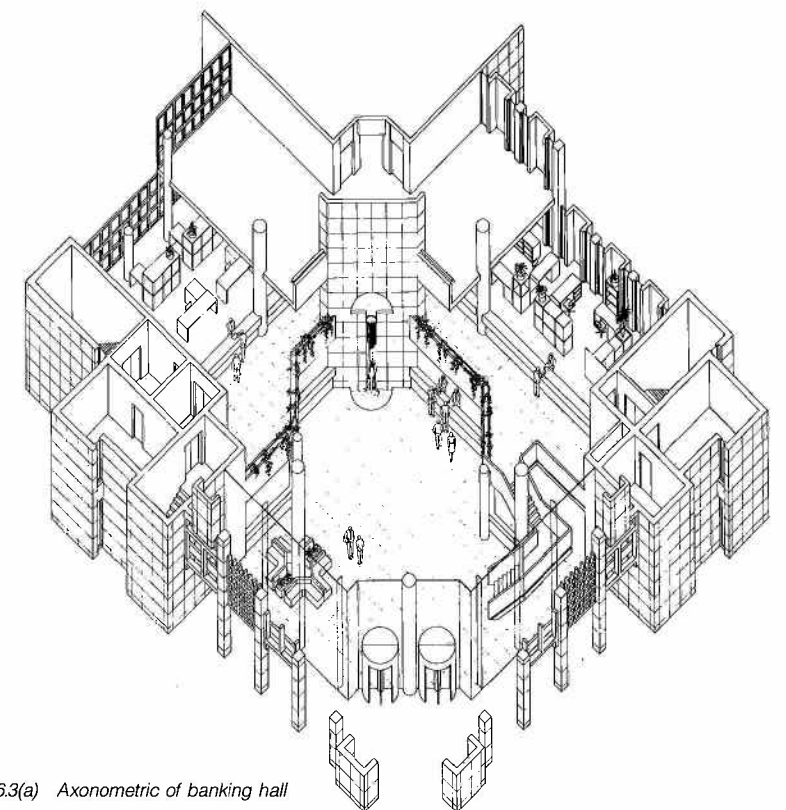
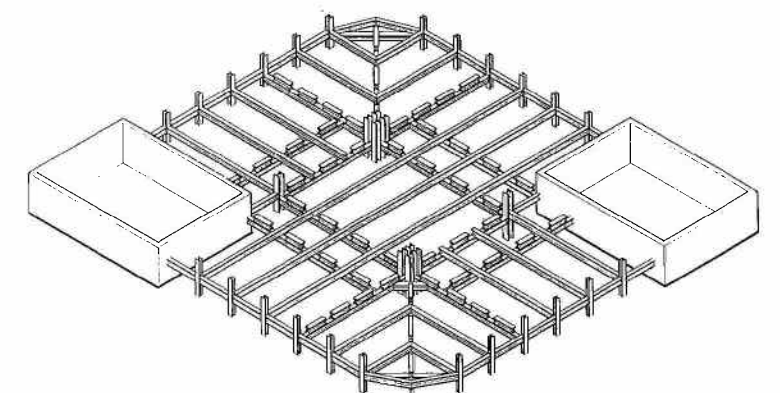

Fig 6.3(a) Axonometric of banking hall

Fig 6.3(b) Isometric of typical floor



**Project Data**

**Client** Amanat al Assima, Baghdad  
**Architect** Sheppard Robson in association with Alousi Associates Test Services, Baghdad  
**Civil and Structural Engineers** Buro Happold  
**Mechanical and Electrical Engineers** J Roger Preson  
**Quantity Surveyors** Hanscomb Partnership  
**Landscape Architect** John Kelsey Associates  
**Status** Working Drawings  
**Floor Area** 412,000m<sup>2</sup>  
**Construction Value** £245,000,000

**The Naish Khana Project, Baghdad**

This project is the development of a 40-hectare site in Khadimiya in the north-west of Baghdad. Until the late 1950's the administration of this area of Baghdad was separate from the rest of the city. The area is a small compact community surrounded by farming land dominated by its mosque built to house the tombs of the seventh and ninth of the first twelve Imams. Consequently, it is greatly venerated by the Shia Muslims and attracts one million visitors a year. The holiness of the shrine and the presence of pilgrims affect the area and this has been respected in the design of the Naish Khana buildings which are only 300m from it.

The development contains 421,000m<sup>2</sup> of generally low rise building types and resulting infrastructure for an urban community housing more than 1,000 families. The buildings from single storey to a maximum of 5 storeys accommodate primary and secondary schools; health and social centres; multi-purpose halls; supermarkets and local shops; hotels; offices; multi-storey car parking; stadium; swimming pool; sports hall; recreational park; library; education centre; and auditorium (Fig. 6.4). Underground nuclear shelters are provided for the resident population. Planting within the site is irrigated and water for this irrigation is stored in underground reservoirs. Roads of various categories, from 4-lane dual carriageways to access routes between the buildings into the internal courtyards and services beneath the roads, form the infrastructure linking this new community to the municipal services of Baghdad around the site.

A study of the pedestrian and traffic movement and parking requirements was made jointly with Sheppard Robson, using patterns of bus, taxi, metro and private car usage from the year 2000 Baghdad traffic model. This assisted in the positioning of buildings, roads, junctions and pedestrian routes in relation to the new metro station.

**Geotechnical Design**

The site is covered with fill which varies in depth from some 3 to 7m. The fill lies over silty clays which with depth are gradually replaced by fine and medium sands. There is ground water at approximately 1.5m below ground level. Generally, the one to three storey housing and the smaller scale buildings have spread footings on stabilised fill – it being proposed that the fill is stabilised using dynamic consolidation. The larger scale buildings sit on groupings of 90 ton driven cast in-situ piles. All buildings are designed to withstand seismic forces equivalent to Zone 1 of Uniform Building Code of USA.

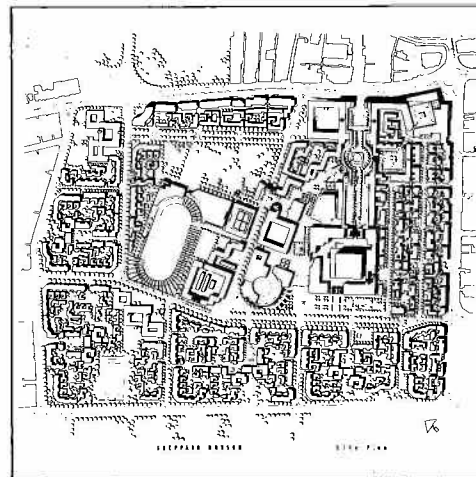

Fig 6.4 Site plan of Naish Khana project

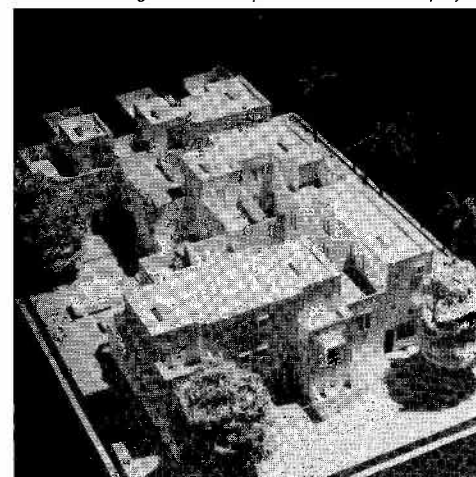

Fig 6.5 Model of housing elements

**Structural Design**

The buildings are generally clad in brickwork although precast concrete is planned for some of the larger ones. The outside walls are made up of the outer skin, a 75mm cavity partially filled with insulation, and an inner skin of blockwork or in-situ reinforced concrete (Fig. 6.5).

Masonry cross walls, precast and in-situ frames, precast panels and in-situ concrete tunnel form alternatives were considered for the construction of the housing units and the residential floors of the hotel. In-situ tunnel form construction as used elsewhere in Baghdad was preferred on grounds of cost, dimensional accuracy, structural integrity and freedom in planning.

The other buildings in the development use a variety of construction techniques and materials selected to suit the individual demands of the building plan form and the overall demands of a major construction site (Fig 6.6).

Structural steel trusses are used for the roofs of the swimming pool, sports hall, the auditorium and the canopy roof to the stadium. Structural steel frames with in-situ reinforced concrete slabs are used for schools. In-situ reinforced concrete rib slabs are used for the car park, State shopping centre and the podium deck between the small shops and the residential units. In-situ concrete frame and slab construction is used for the library, the Pilgrim Hotel, the education centre, the auditorium and the small shops, and flat slab construction is used for the offices and the hotel reception floor. Precast concrete construction is used for the roof to the covered market and the terraces to the stadium.

Rod Macdonald

Fig 6.6 Artist's perspective of Naish Khana development

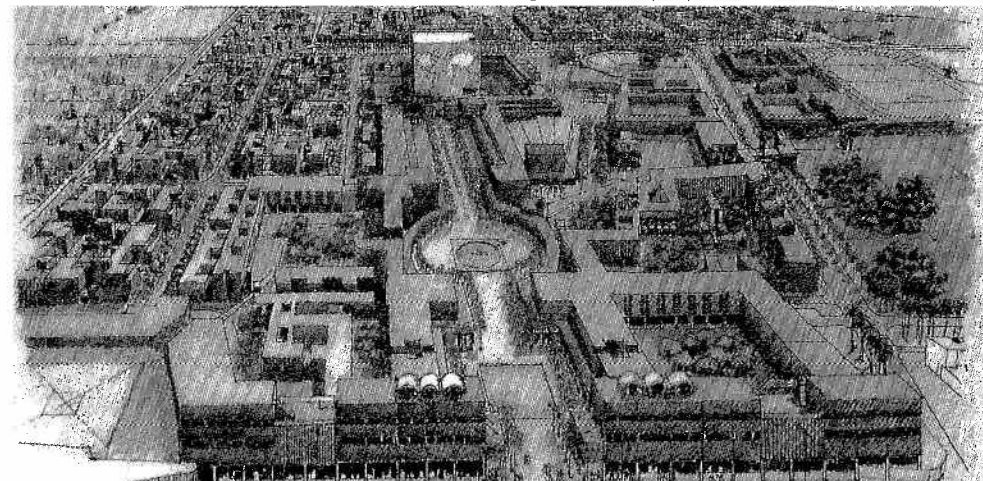

**Project Data**

**Client** The Ministry of Antiquities and Tourism Project Director: Dr Yusef Alami  
**Design Team** Michael Brawne & Associates – Architects  
 Buro Happold – Civil/Structural and Service Engineers  
 Arabtech – Architects, Engineers and Quantity Surveyors  
 Robert Adams  
**Landscape Consultant** Basil Gray  
**Museum Consultant** Basil Gray  
**Date** 1979  
**Area** 5,500m<sup>2</sup> (3,500m<sup>2</sup> Gallery Exhibition and storage space)  
**Cost** JD 1.5m

Petra, Jarash and Crusader castles are all part of Jordan's considerable archaeological heritage (Ref 1). Amman is the fast expanding capital of Jordan and has at its centre, raised on a plateau, a Roman Citadel containing a Temple of Hercules, a Roman water cistern, a Byzantine temple, an Umayyad palace and a small existing museum. It is itself the object of continuing archaeological excavation.

In 1979 as a result of encouragement by the British Council, the Ministry of Antiquities and Tourism appointed the joint venture to design a new archaeological museum to replace the small existing museum and to reclaim the citadel from the ravages of goats. The aim was to provide an archaeological park in which to view the various temples and to contain a new museum as the focus for Jordan's archaeological wealth.

**Climatic and Physical Influences of the Site**

The citadel is exposed and offers little protection from the prevailing dry, dusty south westerly desert winds in the summer or the westerly Mediterranean winds of winter which bring rainfall. In winter the temperature drops to as low as 1°C and surprisingly snowfall is not uncommon, so buildings require heating. In summer mean temperatures in August rise to 29.5°C but fortunately the daily temperature range in the summer is 8°C and the atmosphere dry. Free night cooling of buildings can then be effective when massive construction is used.

The construction industry in Amman has a tradition of dressed limestone construction and load bearing masonry coupled to simple reinforced concrete plate elements. However, with the probability of an earthquake achieving Richter Scale 6 once in 86 years, good structural continuity of all elements is

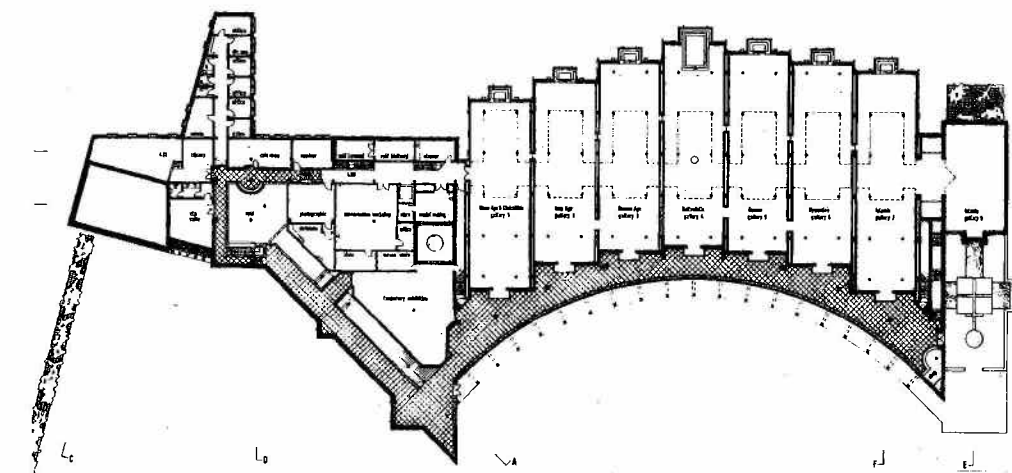

Fig 7.2 Plan of gallery level of museum

necessary (Ref 2).

**Location and Landscape**

The new museum is located at the top of the eastern slope of the upper citadel in a partly excavated area adjacent to the existing museum. The new building then places its back to the prevailing summer wind and glimpses of the surrounding landscape and temples can be had from the museum (Fig 7.1).

Landscaping is concentrated in the upper citadel with parking for fifty cars and five buses located on the lower citadel adjacent to the entrance road from the town below.

Extensive irrigation requirements for the new planting were to be provided by a 500m<sup>3</sup> reservoir beneath the new museum linked to a 1,250m<sup>3</sup>

Fig 7.1 Model of museum site

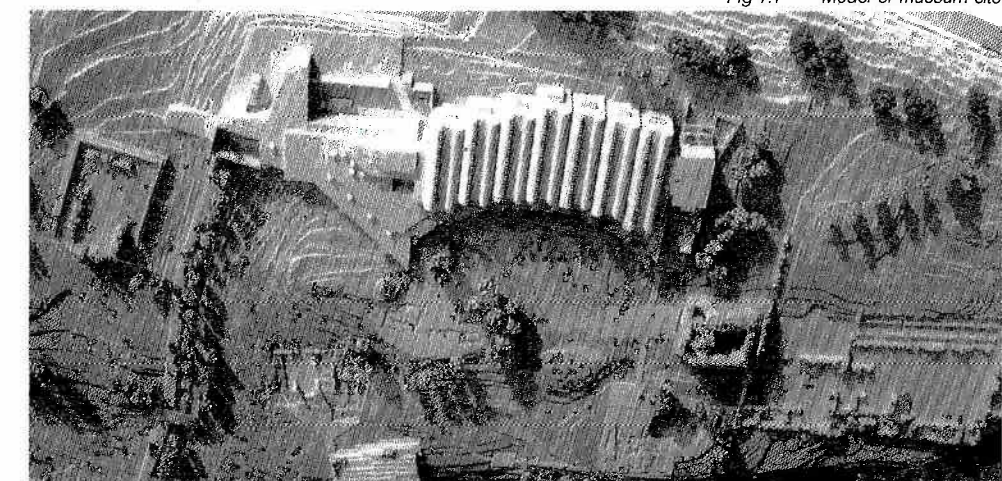

reservoir located on the lower citadel, collecting the surface water winter run off from the buildings and surrounding hardstandings and allowing economical distribution during the dry summer months via a 40m grid of stand pipes. Limited new fencing was to be installed around the perimeter of the upper citadel to exclude further ravages of the goats.

**The Museum**

The style and nature of the new construction was to be evocative of other ancient stone constructions on the site and the museum was to be built in two phases (Fig 7.2).

Phase 1 consists of the galleries at upper level, their undercroft and plant rooms. Phase 2 contains the walled entrance courtyard with water features, reception, library and lecture theatre at the lower level and VIP rooms, administration offices, exhibition and conservation rooms at the upper level. Entrance to the main galleries at the upper level is via a stair in descending flights directly off the foyer area.

The theatre, exhibition and conservation rooms are designed in triangular fairfaced reinforced concrete waffles 600mm deep overall on reinforced concrete columns and walls. Conventional VAV air conditioning systems were to be installed in these areas to give a winter temperature of 21°C and a maximum summer temperature of 25°C and 45–65% relative humidity. Offices, library, and administration areas are designed in 250mm reinforced concrete slab construction to be naturally ventilated in the summer and to receive heat from conventional radiators in the winter. Plant room, chillers etc are located in the core area at the rear of the lecture theatre and built with Phase 1.